



Dear customer

Thank you very much for your order placed with us.

To ensure a smooth operation, we kindly ask you to observe the enclosed Kannegiesser delivery- and operating instructions. The specified services and general regulations are required for the delivery, commissioning, start-up and use of Kannegiesser machines and systems and shall be provided on site. If necessary, these delivery- operating instructions should be forwarded to your coordinator or technician for technical building systems.

With best regards

Herbert Kannegiesser GmbH

Delivery- and operating instructions

Table of Content

1. General regulations for a successful installation and commissioning	6
2. Safety fence	9
2.1 Safety fence for ironer lines	9
2.2 Safety fence for lift conveyors, shuttles and lift-shuttle conveyors.....	9
3. Tunnel washers.....	10
3.1. Setting up the machine.....	10
3.2 Spatial reflection	10
3.3 Medium connections.....	11
3.3.1 Electrical connection.....	11
3.3.2 Water	11
3.3.3 Waste water.....	13
3.3.4 Steam	13
3.3.5 Compressed air.....	14
3.3.6 Exhaust air.....	14
3.3.7 Chemicals.....	15
3.4 Medium quality.....	16
3.4.1 Fresh water	16
3.4.2 Steam	16
3.4.3 Washing liquor	17
3.4.4 Compressed air.....	17
4. Dryers	18
4.1 Setting up the machine.....	18
4.2 Gas-heated dryers.....	18
4.2.1 General.....	18
4.2.2 Exhaust air ducting.....	19
4.2.3 Exhaust air line.....	20
4.3 Steam-heated dryers	22
4.3.1 General information.....	22
4.3.2. Installation of steam- and condensate lines.....	22
4.3.3 Expansion of supply lines.....	23

Delivery- and operating instructions

4.3.4 Discharge of condensate.....	24
4.3.5 Routing of the steam pipework with a descending gradient.....	24
4.3.6 Drainage of supply lines.....	25
4.3.7 Routing of steam line.....	27
4.4 Required utilities connections.....	28
4.4.1 Compressed air.....	28
4.4.2 Escape air and exhaust air.....	29
4.5 Medium quality.....	32
4.5.1 Steam	33
4.5.2 Compressed air	33
5. Washer Extractors.....	34
5.1 Setting up the machine.....	34
5.2 Machine in barrier wall execution	35
5.3 Installation of steam- and condensate line.....	35
5.3.1 Expansion of supply lines.....	36
5.3.2 Discharge of condensate.....	37
5.3.3 Routing of the steam pipework with a descending gradient.....	37
5.3.4 Drainage of supply lines.....	38
5.4 Medium connections.....	40
5.4.1 Electrical connection	40
5.4.2 Water	40
5.4.3. Waste water.....	41
5.4.4 Exhaust air.....	41
5.4.5 Steam	41
5.4.6 Compressed air.....	42
5.5 Medium quality.....	42
5.5.1 Fresh water	42
5.5.2 Steam	43
5.5.3 Washing liquor	43
5.5.4 Compressed air.....	43
6. Ironers.....	44
6.1 Installation of steam- and condensate lines.....	44
6.1.1 Expansion of supply lines.....	45

Delivery- and operating instructions

6.1.2 Discharge of condensate.....	46
6.1.3 Routing of the steam pipework with a descending gradient.....	46
6.1.4 Drainage of supply lines.....	47
6.2 Medium connections.....	50
6.2.1 Compressed air.....	50
6.2.2 Escape air and exhaust air.....	50
6.2.3 Exhaust gas.....	52
6.3 Medium quality.....	53
6.3.1 Steam.....	53
6.3.2 Compressed air.....	53
6.4 Advice for gas-heated ironers.....	54
7. Tunnel finisher.....	55
7.1 Steam-heated tunnel finisher.....	55
7.1.1 Steam line.....	56
7.1.2 Condensate line.....	58
7.2 Gas-heated tunnel finisher.....	59
7.2.1 Gas line.....	60
7.2.2 Outlet air line.....	61
7.2.3 Outlet air ducting.....	61
7.2.4 Advice for gas-heated tunnel finisher.....	62
7.3 Medium connections.....	63
7.3.1 Electrical connection.....	63
7.3.2 Extinguishing device (optional).....	64
7.4 Outlet air line.....	65
7.5 Other directives and regulations.....	66
8. RFT.....	67
8.1 Range of articles.....	67
8.2 Alignment of articles and folding pattern.....	68
8.3 Sorting on the folding machine.....	68
9. Network.....	70
9.1. Teleservice.....	70
9.2. DataExchange Gateway.....	74

Delivery- and operating instructions

9.3 Order processing contract according to GDPR (General Data Processing Regulations).....	75
10. Proper storage of machines.....	76

1. General regulations for a successful installation and commissioning

- Access roads to/from factory premises shall be created, passable and cleared. Preparing the access to the installation site. Storage space for machines, lorries, canes, fork-lifters, scrap bins and other vehicles shall be ensured on site.
- Upon delivery of machines, waste containers for the disposal of packaging and transport materials must be available at site.
- Access of the installation personnel as well as as well as accessibility of the installation equipment must be ensured.
- The facility must be secured all-around.
- During idle period, the facility must be secured against access by third parties (lockable windows, doors and gates, etc.). Should the building can not be secured, safety (against vandalism, theft etc.) must be guaranteed, for example by a security company.
- The floor load-bearing capacity at the installation site as well as opening for machine entry must be guaranteed during installation.
- Prior to installation, fastening of machines and systems to other trades on site shall be possible.
- All constructional services specified by Kannegiesser such as pits, floor inlets, platforms, etc. must be established on site prior to starting assembly.
- Heated buildings must be provided, especially during winter season.
- The building must be sufficiently illuminated and ventilated.
- Sufficient sanitary facilities shall be provided for the installation staff.
- For installations lasting several days, a lockable room to store tools as well as a dressing room for the technicians must be available. An adequate container shall be rented, if necessary.

Delivery- and operating instructions

- Prior to installation, the technicians must be given a safety briefing (for example on escape routes, position of fire extinguishers, emergency phone numbers, coordination with other trades).
- At the beginning of installation work, at least site electricity must be available.
- Power connection with approx. 63 A, 3x400V 50 Hz, PE must be available at the beginning of the press assembly, at least temporarily when ramping the press up.
- It is the client's responsibility to coordinate between the trades involved in this project and Kannegiesser.
- It must be ensured that all fitting companies (responsible for electrics, steam, condensate, gas, compressed air, supply/exhaust air, data processing, washing chemicals, etc.) comply with the previously agreed assembly schedule.
- The customer is obliged to obtain any legally required approvals for constructional or assembly measures.
- At the beginning of the commissioning, the customer has to provide the quantity of test linen and customer linen requested by Kannegiesser, as well as the required number of operators.
- A sufficient number of operational technicians are mandatory for training and instruction during implementation.
- The detergent technician must be invited and shall be available upon start of commissioning.
- Cleaning and maintenance of the machines after commissioning must be ensured.
- Media supply must comply with and be finished according to the assembly schedule previously agreed with Kannegiesser.

- If necessary, the following lifting devices and equipment must be provided for assembly work; details shall be coordinated with the Kannegiesser project team :
 - Crane
 - Fork-lifter
 - Electric lift trucks
 - Scissor platforms
 - Heavy-duty telescopic lift for platform installation
 - Covering plates to protect floor inside/outside (in the case of channels, pits or areas with insufficient load capacity)
 - Load-distributing or load-absorbing devices in the event of insufficient load-bearing capacity
 - Carriages, cover plates, columns, etc.
- For removal or assembly of machines, for example in case of a press replacement, all paths in the basement must be supported, if necessary.
- For scrapping machines on site, scrap bins or storage area must be made available and/or defined. In this case, the scrap agent shall be informed of the assembly schedule.
- After machine installation, all machines must be protected from moisture, dust or other soiling.

2. Safety fence

2.1 Safety fence for ironer lines

Under current regulations and to secure a safe operation of the ironer line, it is mandatory that there is a fencing on site between feeding unit and ironer or between ironer and folding machine, respecting the local standards valid at that time. This fencing can be optionally offered by Kannegiesser.

2.2 Safety fence for lift conveyors, shuttles and lift-shuttle conveyors

Under current regulations and to secure a safe operation of the lift conveyor, the shuttles and the lift-shuttle conveyor, it is mandatory that there is a fencing to be installed on site. The corresponding door key system shall be supplied by Kannegiesser. This fencing can be optionally offered by Kannegiesser.

Delivery and operating instructions

3. Tunnel washers

3.1. Setting up the machine

Place the machine on a sufficiently load bearing and level concrete floor. It is also possible to set up the machine on a base having a sufficient load bearing capacity - e.g. on a steel structure.

Adhere to the following:

- Information in section "Technical data"
- Information in chapter "Transport and stability"
- The installation plan
- The space requirement for service work and operation. Provide a safety perimeter of minimum 0.5 meters around all accessible machine parts, on the operating side 1 meter, to the top 1.3 meters.
- the space requirement at the guards in the infeed and outfeed area
- the position in relation to the supply and return connections (three-phase current, water/waste water, air, steam).
- For unloading the machine, use a crane with a transport traverse bar. Ensure that the machine is suspended horizontally in the crane during unloading.

Only remove the transport safety devices when the machine is positioned on the intended installation site.

3.2 Spatial reflection

Walls, ceilings and floors reflect the sound directly emitted by the machine. The reflection adds to the directly emitted sound. To reduce the spatial reflection and the sound level at the workplace:

- Install the machine in a room with a high ceiling.
- If the walls or ceilings are made of sound-reflecting materials, attach materials to ceilings or walls that absorb the sound.
- Install sound protection walls
- Sound emission by air flow
- Install compressed air mufflers

3.3 Medium connections

The installation, routing and connection of all lines to the machine (including the required locking valves) as well as the power supply lines to the switch cabinets are the responsibility of the customer and are not part of the delivery scope !

For the position of the respective medium connection (cold water, exhaust water, steam, compressed air and exhaust air), please refer to your installation plan!

3.3.1 Electrical connection.

How to carry out the electrical installation:

- Have the electrical connections at the switch cabinet established by an electrician in accordance with the regulations (200 - 600 VAC, see electrical wiring diagram).
- Establish the connection to the controls of the adjacent machines (see electrical wiring diagram).
- Check the function of all protection devices/guards (Emergency Stop switches, light barriers, protection relays, earth resistor etc.) and adjust the protection devices/guards, if necessary.
- Test all control and measuring systems

3.3.2 Water

Connect the machine to the water supply (cold soft water) and take note of the following instructions:

- A customer-supplied manual locking valve and a dirt trap must be installed directly upstream of the machine.
- Water pressure 0,2 - 0,4 Mpa flow pressure !

Assembly instructions for NORMA CONNECT clamp fittings

Adhere to the following information if NORMA CONNECT clamp fittings are used for assembly:

- Check pipe ends. Remedy damage in the area of the sealing lips, such as burrs, longitudinal grooves, cracks etc. and remove coatings, such as paint, rust etc.

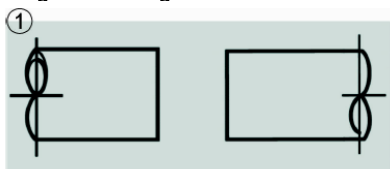

- Mark half of the coupling width on both pipe ends.

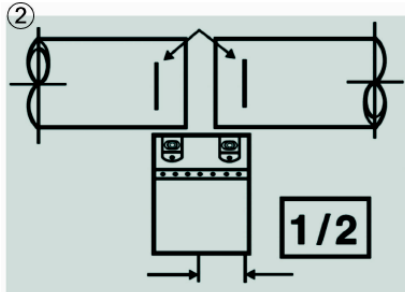

- If applicable, remove transport securing elements and remove possible dirt particles from the sealing surface. Do not dismantle the coupling! Do not drop the coupling!

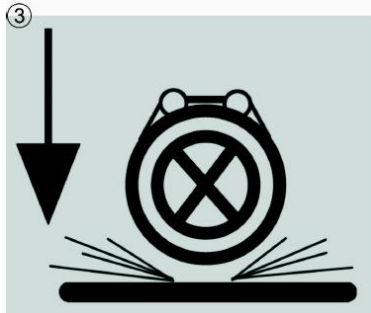

- Then slide on the coupling and align with the marks on the pipe ends. Slightly tighten the screws alternately using a ratchet or screwdriver. Stop turning the coupling once the coupling teeth are in engagement with the pipe. Use a dynamometric key to alternately tighten the screws.

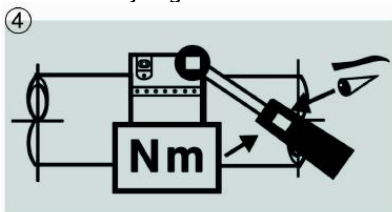

Attention:

Never exceed the tightening torque specified for the plug screws. In the event of leaks encountered after assembly, dismantle the coupling and focus again on points 1 to 4 (note: cleanliness of the sealing areas and pipe surfaces.)

Torque	
Size	Torque (Nm)
EP 26,9	10
EP 33,7	10
EP 38,0	15
EP 48,3	15
EP 60,3	20
EP 76,1	30

3.3.3 Waste water

Connect the machine to the water supply and take note of the following instructions:

- Ensure that the specified nominal width of the pipework is not reduced at any point.

3.3.4 Steam

Connect the machine to the steam supply and take note of the following instructions:

- A customer-supplied manual locking valve must be installed directly upstream of the machine!

High-pressure steam connection:	See installation drawing!	
Steam pressure (high-pressure):	All types:	0,25 0,8 Mpa (2,5 - 8bar)
Low-pressure steam connection:	All types:	upon request
Steam pressure (low pressure):	All types:	0,1 - 0,24 Mpa (1 - 2,4 bar)
Other heating media:	upon request	

3.3.5 Compressed air

Connect the machine to the compressed air supply and take note of the following instructions:

- Connect the compressed air line directly to the air servicing unit of the machine (stop cock required on site!). Ensure a sufficient line cross section (at least R 1/2"), particularly for greater distances to the compressor.

Connection line:	See installation drawing!	
Air pressure:	All types:	0,60 MPa (6,0 bar)

The compressed air may be uniled.

3.3.6 Exhaust air

The machine can be optionally equipped with an exhaust air connection. The exhaust air ventilator is equipped with a throttle valve. If required, this throttle valve can be used to set the exhaust air quantity.

Connect an exhaust air line to the machine.

Please take note of the following instructions:

- Provide a sufficient pipework cross section (minimum diameter 200 mm = size of connector socket).
- Never reduce the cross section of the exhaust air line.
- Enlarge the pipe cross-section if the pipe is more than 5m or when using more than 2 pipe-angles! Ensure that accumulation lines have a larger cross section than the sum of all connection piece cross sections.

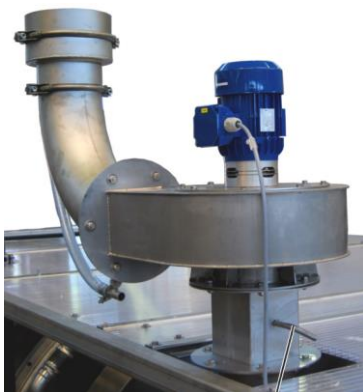

Bends:

- Provide a sufficient pipework cross section (minimum diameter 200 mm = size of connector socket).
- Ensure that the exhaust air line is routed as short and straight as possible to the open! Every change of direction will increase the resistance! Sharp knees or angles will particularly increase the aerodynamic resistance.
- Ensure a minimum radius for bends of $0.5 \times D$ (pipe diameter).

Termination:

- If the exhaust air line is guided upwards to the open, a cover must be fitted on top of the exhaust air pipe. A Meidinger disk, the diameter of which is twice the pipe diameter, has proven as a cover and must be fitted at a distance of $0.5 \times D$ above the exhaust air line end. This will prevent an increase in aerodynamic resistance by turbulence.
- Ensure that the exhaust air discharge is routed as short and straight as possible to the open. Every change of direction will increase the resistance! Sharp knees or angles will particularly increase the aerodynamic resistance.
- Do not install strainers or louvres as a termination of the exhaust air discharge.

3.3.7 Chemicals

Recommended chemical connections

Detergents / Auxiliary washing agents	Media box LH-steam side	Media box RH	Outer drum -"10 o'clock"-positions
Detergents / Auxiliary washing agents	X	X	XX
Alkali intensiyer	X	X	XX
Tenside mix	X	X	XX
Softener	X	X	XX
Acid	X	X	XX
Peracid	-	X	XX
Active chlorine	-	XX	-
Starch	X	X	XX

XX	Preferred chemical connection
X	Dosage admissible
-	Dosage prohibited

3.4 Medium quality

The water, steam and compressed air quality provided by the customer must comply with the generally accepted state of the art. The following limit and reference values apply:

3.4.1 Fresh water

At the entrance of the machine, the following fresh water quality is demanded:

- Iron content max. 0.1 mg/l
- Maximum copper content: 0.05 mg/l
- Maximum manganese content: 0.03 mg/l
- Chloride content max. 200 ppm (water should not react corrosive)
- Max. total hardness: 0.1 mMol/l Ca/Mg alkaline earth ions (0.56 °dH / 1 °f / 0.7 °E)
- Check carbonate hardness regularly and adjust chemical dosage accordingly (> 15 °dH may lead to problems)
- Check conductivity of fresh water regularly (if necessary, adjust process and chemical dosing accordingly)
- Hygienic (max. 100 cfu/ml, no pathogenic germs, no spores)

3.4.2 Steam

At the entrance of the machine, the following steam quality is demanded:

- Conditioned soft water and boiler water according to DIN EN 12953-10:
 Conductivity of boiler feed water: reference value = 3500 µS/cm, limit value = 6000 µS/cm
 Conductivity of condensate : < 10 µS/cm
- Max. iron content: 0.1 mg/l.
- Max. flow speed 25 m/s.
- For the use of long-distance heating, the same requirements apply as for fresh water.

3.4.3 Washing liquor

The following washing liquor quality is demanded inside the machine:

- Max. active chlorine content: 250 ppm.
- Max. active oxygen content: 500 ppm.
- Wash temperature 40-95 °C.
- pH value in the washing area > 7, in the neutralization chamber > 5.5.
- Check regularly the conductivity difference between fresh water and extracted liquor (Delta > 1000 µS/cm may lead to problems).

3.4.4 Compressed air

Adhere to the following compressed air quality according to ISO 8573-1:2010, class 7.4.4:

Class	Solid particles Mass concentration [mg/m ³]	Water Dew point under pressure, steam [°C]	Oil Total oil ratio (liquid, aerosol and fog) [mg/m ³]
1			
2			
3			
4		≤ +3	5
5			
6			
7	5-10		

Delivery and operating instructions

4. Dryers

4.1 Setting up the machine

When selecting and equipping the installation site, please adhere to the following:

- Guide the dryer exhaust air to the outside, otherwise the likelihood of the following hazards may increase: The concentration of unhealthy gases, the generation of inflammable dust, the danger of poisoning and explosion.
- Never store flammable material near the dryer, e.g. aerosols.
- Never spray aerosols near the dryer.
- Never operate gas-heated dryers in the same room as chemical cleaning machines.

The dryer can be mounted in the following two ways:

- Screwed with steel beam (platform installation)
- Fastened in concrete with adhesive anchor (pedestal installation)

The supplied adhesive anchor cartridges are approved for undrawn concrete with a compressive strength class higher than C20/25. If type of concrete does not comply with these requirements, provide a suitable fastener on site, such as dowels

4.2 Gas-heated dryers

4.2.1 General

Never operate gas-heated dryers in the same room as chemical cleaning machines. Chlorinated hydrocarbons, even excessively diluted, lead to the formation of hydrochloride acid in gas heaters.

Corrosion damage will occur within a brief period (even on "rust-proof steel") and laundry items will be damaged. Only allow an authorized expert to carry out connection work taking the relevant regulations at the installation site into account. The customer-supplied gas supply line must be equipped with an equipotential bonding device. Do not operate the dryer outdoors. The dryer is only suitable for operation in closed and sufficiently vented rooms. For installation observe and adhere to the specifications in the dimension and data sheets as well as the assembly and installation instructions. Prior to first start-up and after modifications on the exhaust gas (exhaust air) system, have the machine line inspected according to DVGW G631 by the appropriate authorities. Outside Germany, observe and adhere to the technical regulations valid for the country of destination. Ensure that the burner is only operated with the types of gas specified on the machine type plate. Ensure that the gas connection pressure does not exceed the admissible connection pressure.

4.2.2 Exhaust air ducting

The gas-heated PowerDry is seen as industrial process system according to EN 746-2 and does not require DVGW certification (German association for gas and water). All series comply with the relevant regulations/directives.

Due to the respective burner capacities, a certain proportion of exhaust gas per hour is generated by stoichiometric combustion of gas. This proportion is included in the process air of the dryer. The air and exhaust gas mixture is extracted via the ventilator and transported to the outside by means of the exhaust air line to be installed on site.

The air and exhaust gas mixture, which is defined in the DVGW sheet G 631 A, is to be classified as exhaust gas, and not as exhaust air. The exhaust gas must be properly discharged via exhaust gas line/exhaust gas system.

The relevant standards, such as DIN EN 1443, DIN EN 15287 - 1 are to be considered. We recommend to instruct an expert company for technical execution.

A certified district chimney sweep must be contacted.

Pipe system made of metal tubes to discharge exhaust gas must be state of the art. Only use certified chimney pipes. We recommend the use of corrosion-resistant stainless steel when selecting the material of the exhaust gas pipes. For D series, exhaust air temperature is max. 140°C. When selecting components, consider the corresponding directives according to the respective state building regulations.

An insulated pipe construction is advantageous to avoid that condensate is formed in the exhaust air pipe as far as possible. Exhaust gas emerging into the room is not admissible.

The exhaust path control is required. Prior to the installation of the exhaust gas system, the suitable check and control openings must be adjusted by a certified district chimney sweep. Have the exhaust path control checked once per year according to the pertinent regulations.

Dryers are not subject to the 1st federal immission control act Germany (cf. §1, Para 2 No. 2 1. BImSchV) and therefore no exhaust gas loss or immission measurement (CO) is prescribed (German chimneys sweeper and control act KÜO of 16 June 2009).

Further technical information on exhaust air and exhaust gas hygiene is available from the factory on request. Please contact your local Kannegiesser representative if required.

4.2.3 Exhaust air line

Along with the escape air, flue gases are exhausted through the exhaust air line. For this reason, we recommend that the exhaust air line is designed as follows:

- For technical execution, we recommend an exhaust air system supplier (e.g. Westaflex Gütersloh/Germany) and/or a local specialized crafts enterprise. The inside pipes should be made from stainless steel quality Cr Ni 18 8, in particular material no. 1.4571. Low alloy steel and/or galvanized finishes are less suitable due to the corrosion susceptibility and the expected lower service life. Final selection of the components is at owner's discretion. Consider especially the corresponding directives according to the respective state building regulations.
- Seal all cutting points or seams. Use temperature-resistant sealing material, e.g. silicone glue or sleeves.
- Provide control openings for exhaust path controls. (Position and size according to responsible sweep association/guild).
- Do not cover blow-out opening on roof with sieves or screens or similar.

Technical data

For the technical data regarding the exhaust air connection, please refer to the machine data sheet.

General design regulations

Multiple versions are possible depending on the local conditions.

Admissible length of the escaping air pipework

Route the escaping air pipework in a straight line and on the shortest way to the outside. Please refer to the machine data sheet for the maximum back pressure.

Several machines

Never connect several machines to one escaping air pipework. Always install one escaping air pipework for each machine.

Cross section

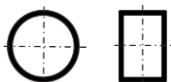

The cross section of the piping may be rectangular or round. We recommend using pipes with a round cross section.

Diameter

The diameter of the escaping air pipework must not decrease in the flow direction.

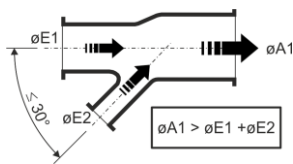
Junctions

Junctions must not be fitted at an angle larger than 30° in the flow direction. Try to avoid Y-tubes. The starting diameter must be larger than the sum of the inlet diameters.

Gradient in flow direction

The gradient in the flow direction may be between 1:100 until 1:200.

Directional changes

Only change directions in small increments. Use pipe bends with a large radius.

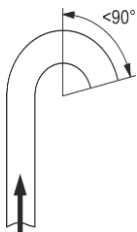
End of the escaping air pipework

Do not end the escaping air pipework with sieves or screens and install a drainage assembly. If the ends point upwards, install a Meidinger disc or end with a pipe bend $< 90^\circ$.

4.3 Steam-heated dryers

4.3.1 General information

To prevent scalding by steam, only allow steam technology experts to carry out the steam installation at the customer's premises. All seals must be suitable for steam and pressure of up to 16 bar.

The machine owner/user is responsible for the connection line installation. The machine is delivered ready to be connected including flange and counter flange.

4.3.2. Installation of steam- and condensate lines

The installation of the steam and condensate lines is in the sole responsibility of the customer. The steam and condensate lines must be installed properly and professionally - in accordance with industry-standard guidelines.

The installation instructions shown are intended to provide basic information to prevent particularly critical installation errors and do not replace a competent installation.

During installation of the steam pipe system, particularly observe the expansion and the discharge of condensate in the pipework.

4.3.3 Expansion of supply lines

Ensure that the longitudinal extension of the supply lines is allowed.

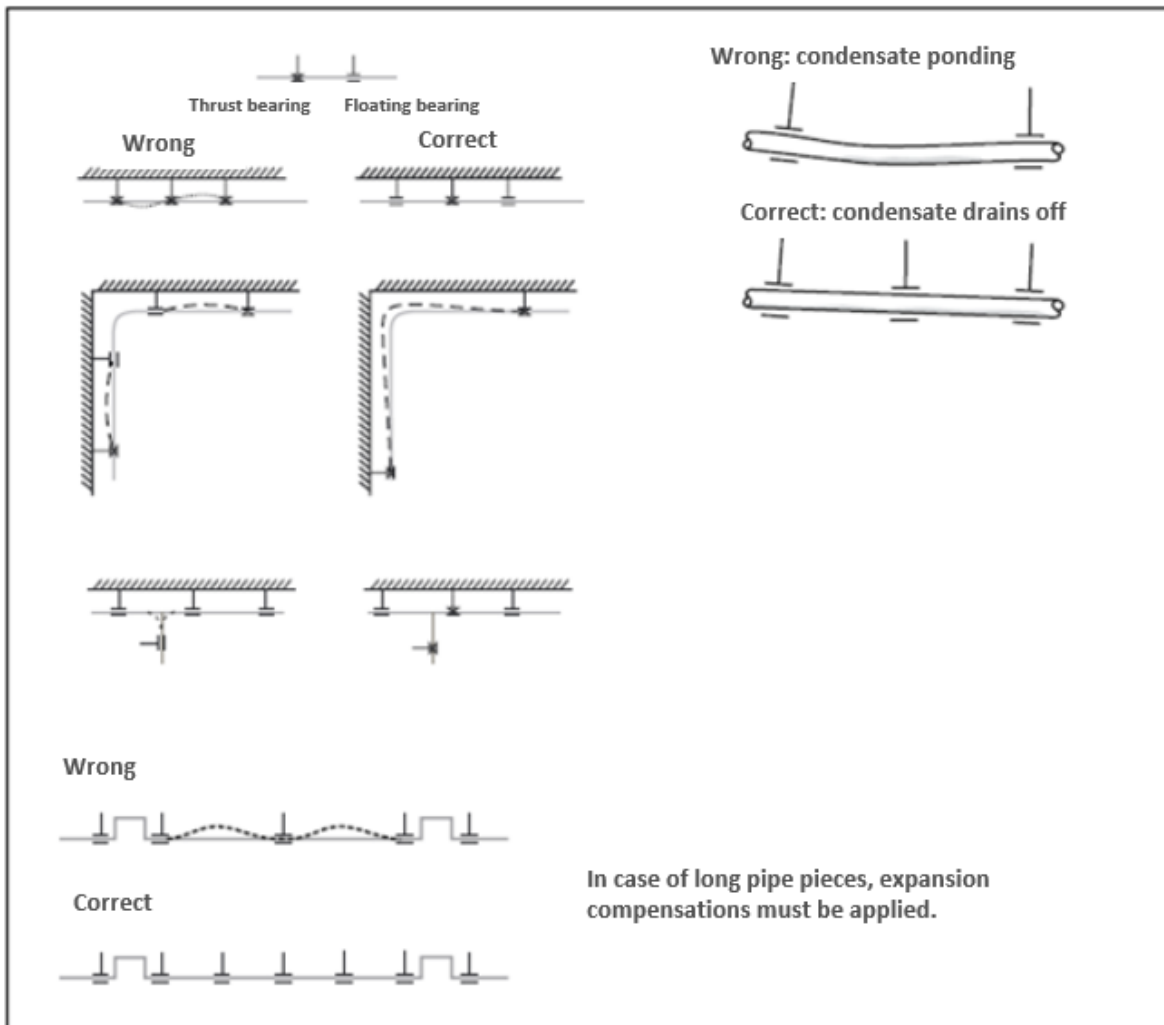

Source: Spirax Sarco GmbH

4.3.4 Discharge of condensate

If condensate is formed in the steam line, the following problems may occur:

- Increased risk of erosion
- Increased loss in pipe friction
- Obstruction of steam flow
- Difficulties in starting the pipe network
- Causing hydraulic pounding in the supply line which could destruct or endanger components and ironer

It is essential to drain the steam line.

4.3.5 Routing of the steam pipework with a descending gradient

Route the steam line in the flow direction with the descending gradient 1:100 to 1:200.

Provide additional condensate lines for pipe sections longer than 25m.

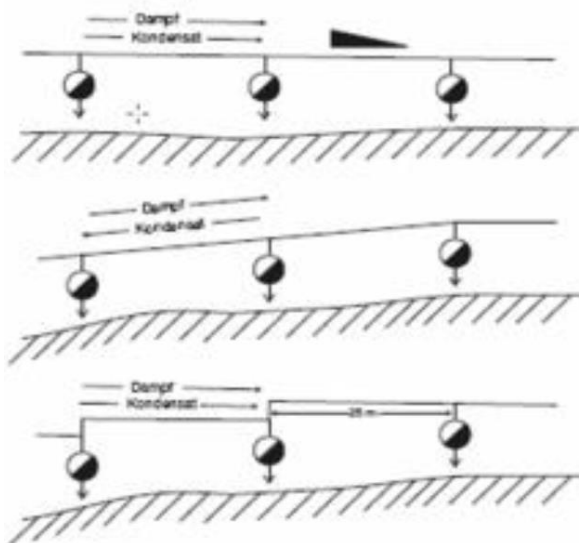

"correct"
standard installation

"wrong"

"correct"
installation with gradient in flow
direction or for larger height difference

Source: Spirax Sarco GmbH

4.3.6 Drainage of supply lines

The low points and ends of the supply pipe must be drained.

Rated width of steam line = rated width of condensate separator

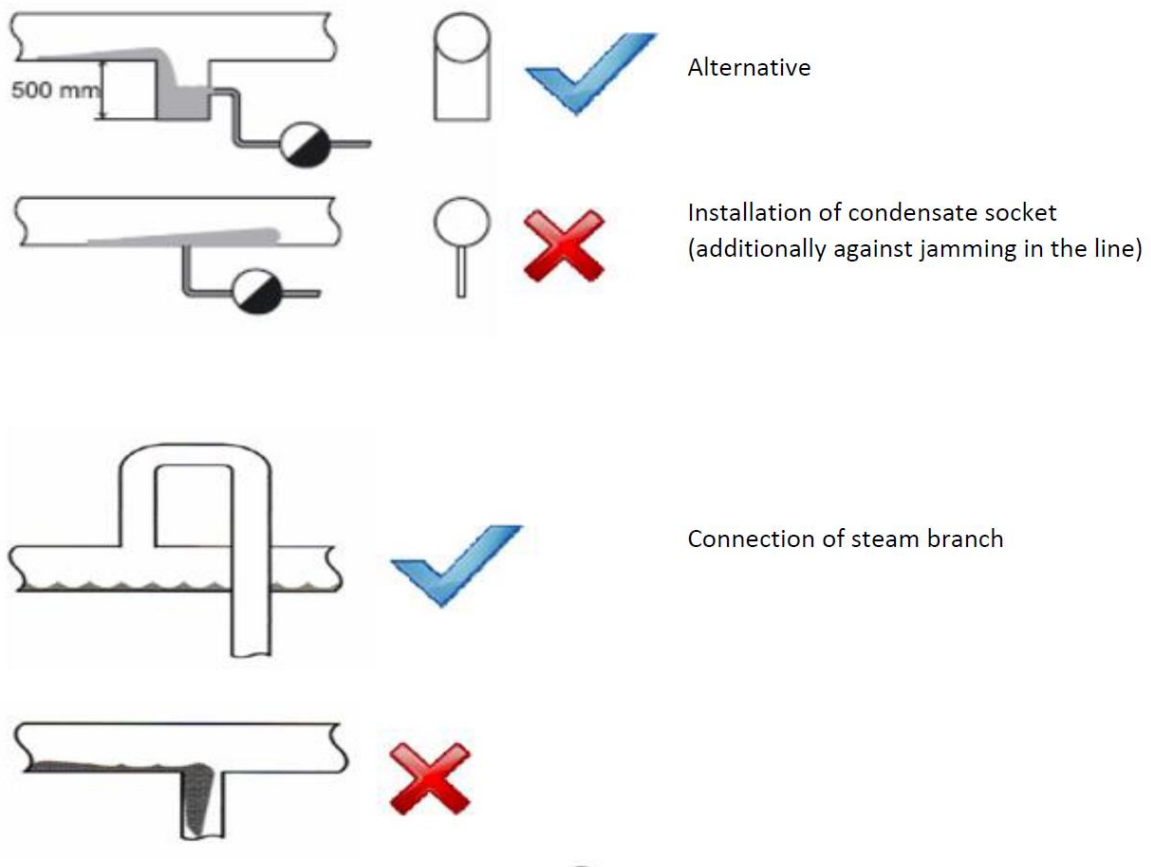

Water drainage directly before dryer

It is necessary to drain the steam line prior to the entrance of the dryer. The drawing shows an example designed by Kannegiesser. This type of drainage is supplied by Kannegiesser.

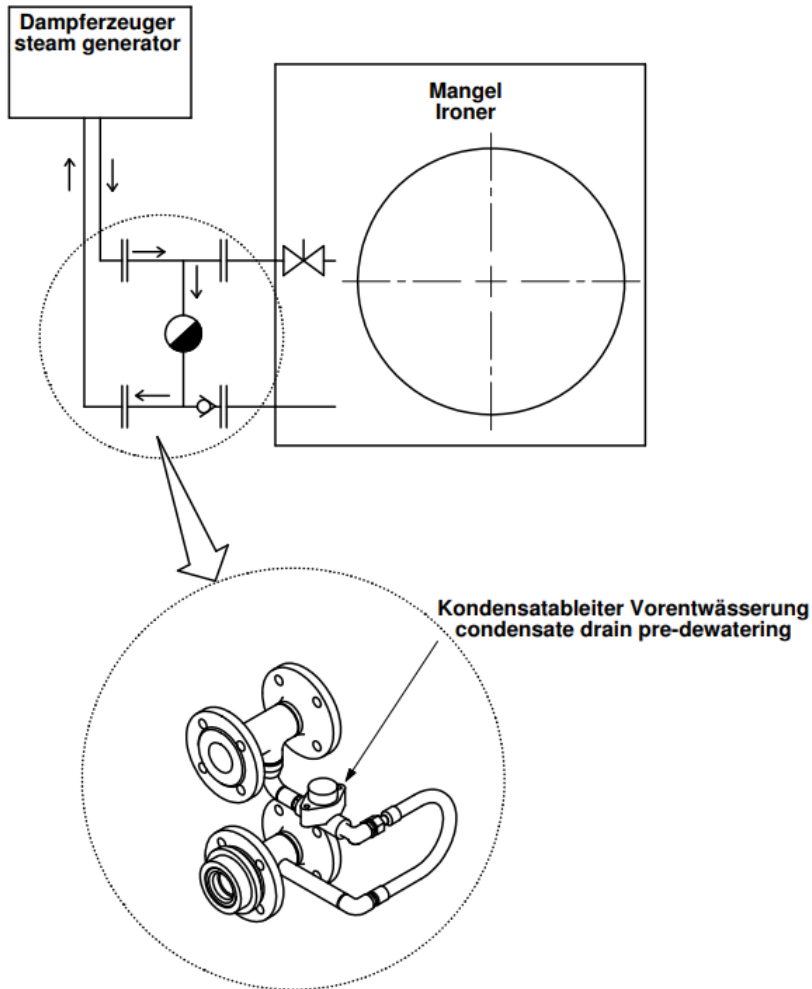

Horizontal execution
Horizontale Ausführung

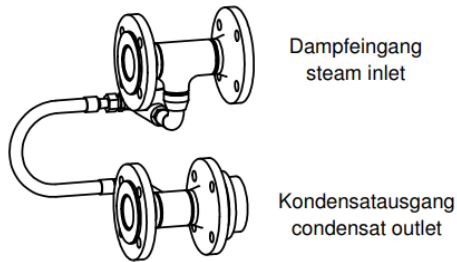

Vertical execution
vertikale Ausführung

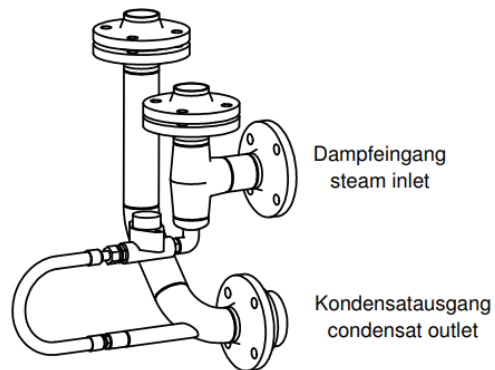

4.3.7 Routing of steam line

Observe the general rules for the routing of steam pipework:

- Ensure that water extraction points are always at all lowest points in the line:

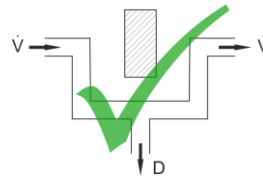

- Route the steam line in the flow direction at an incline. The incline should be between 1:100 to 1:200.

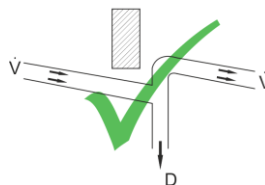
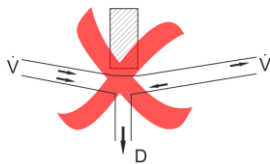

- If the ground rises in the flow direction, install short vertical pipes. In this manner, a saw-tooth cable guide is created when a longer supply line is fitted. Drain the steam line every 25 to 50 metres (27 to 55 yd.).



4.4 Required utilities connections

4.4.1 Compressed air

Compressor performance

The capacity of the compressor should be 20% to 30% higher than the compressed air consumption of the machine to ensure malfunction-free operation.

Supply line material

Install a supply line made of galvanized steel pipe or copper pipe to prevent rust from entering the compressed air system of the machine during operation.

Supply line diameter

Length of supply line	Diameter
≤ 10 metres	1/2"
> 10 metres	3/4"

Prior to connecting the machine, fit an air shut-off valve. Use a compressed air hose to connect the machine with the supply line to prevent the transmission of vibrations. The hose should have a length of approx. 400 mm (15.75 in.) and the same cross-section as the supply line.

4.4.2 Escape air and exhaust air

4.4.2.1 Exhaust air line

Please observe the following installation regulations:

- The best drying result is achieved with a separate exhaust air line as short as possible without any pipe bends.
- The pipe diameter of the exhaust air line is defined by the cross section of the exhaust air socket on the device and may not be selected smaller.
- For pipe lengths of more than 5m or more than two pipe bends in the exhaust air line, use the next larger pipe diameter.
- When selecting a pipe bend, the inner radius R must be at least half the pipe diameter D.
- If several dryers are connected to one exhaust air line, the cross section of the accumulation line must be at least the same size as the sum of all connecting cross sections, or refer to the diameter of the accumulation line as per table.
- Single lines should hit accumulation line at an angle of max. 30°, to prevent the dryers from being influenced by each other. The air flow should be protected by an air guide plate.
- If the exhaust air line has to be discharged upwards and below the ceiling, the lowest point directly at the dryer shall be provided with a condensate drain. The condensate is collected in a container or discharged through a hose line.
- If the exhaust air above the roof or outside on the wall is to be terminated, the so-called Meidinger disc is a simple solution with minimal resistance. Never cover blow-out opening with sieves or screens.

Number of dryers		1	2	3	4	5	6
Min. diameter D of accumulation line	DII40-120	400	560	710	800	900	1000
	DII175/220	500	710	900	1000	-	-

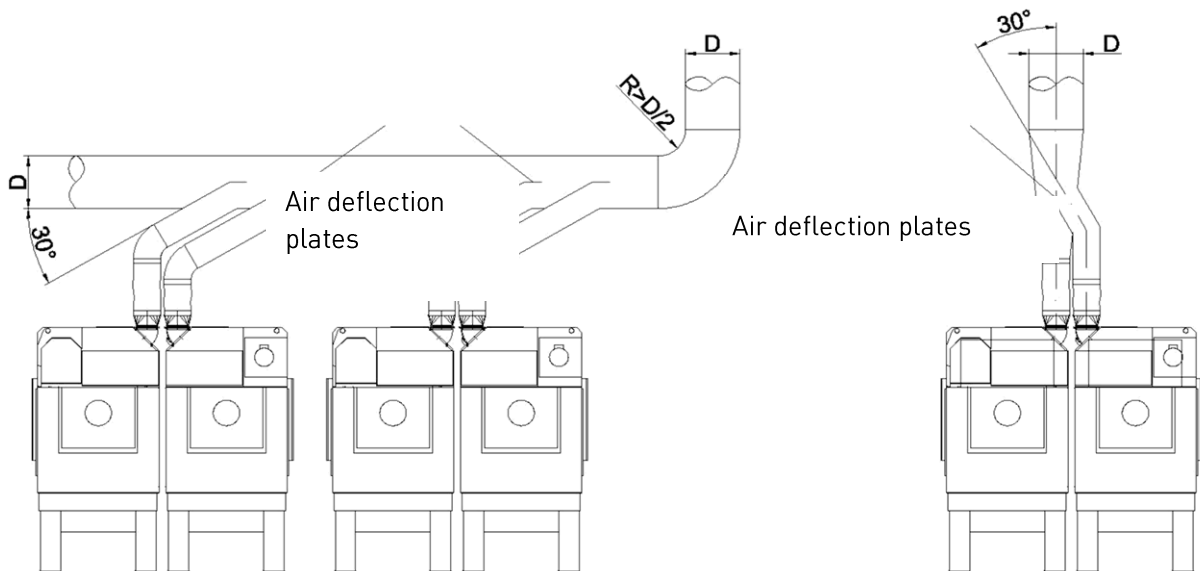

4.4.2.2 Guide of exhaust air line

- Hoses are not suitable for replacing missing exhaust pipe bends.
- Hoses must be shortened to suitable length. Too long hoses form air pockets and reduce the air flow.
- During dryer operation, the behaviour of the exhaust air hose must be viewed and evaluated after installation. Ensure that the hose can not bend in the home position of the machine and that the complete exhaust air cross section is kept.

Above all, the air outlet via the roof is important. It is UNFAVOURABLE, IF

- a rain shield or a china hat is mounted just above the outlet opening. The following applies here: DISTANCE must be at least 1,5x diameter of the pipe, better MORE!
- grilles, to prevent birds from nesting, are installed in the exhaust pipe. After a short time, they will be completely impermeable for air, as they collect lint. Reflective, loosely mounted reflectors would be better to drive birds off.

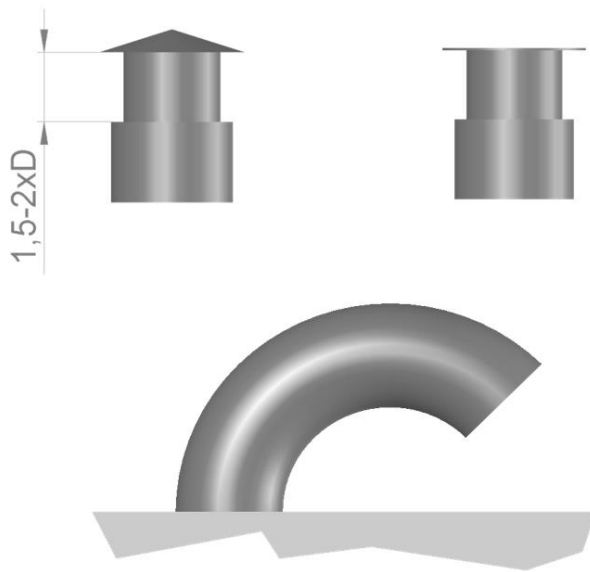

Exhaust air connection to the rear
(preferred solution):

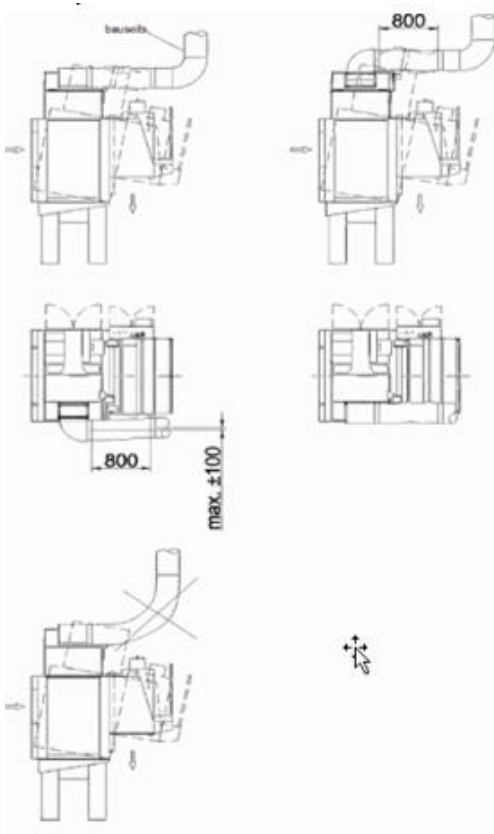

Exhaust air connection upwards

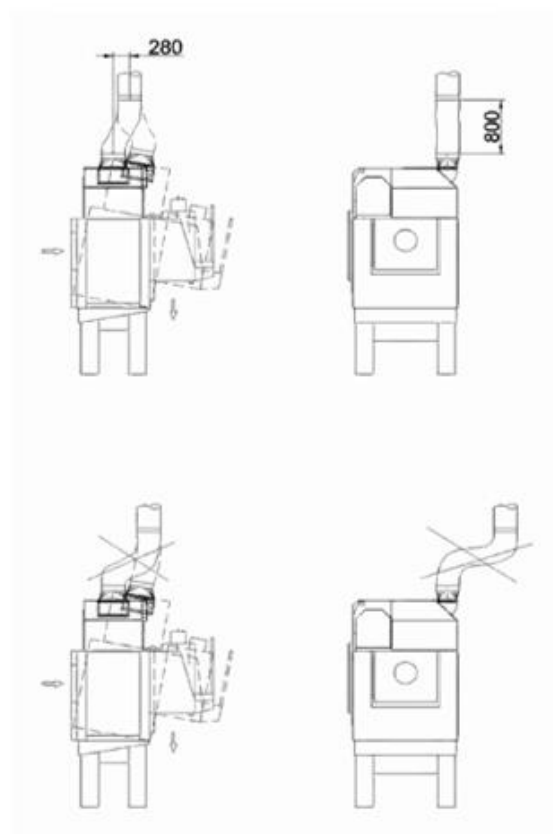

4.5 Medium quality

The water, steam and compressed air quality provided by the customer must comply with the generally accepted state of the art. The following limit and reference values apply:

4.5.1 Steam

At the entrance of the machine, the following medium quality is required:

- Conditioned soft water and boiler water according to DIN EN 12953-10:
 - Conductivity of boiler feed water: reference value = 3500 $\mu\text{S}/\text{cm}$, limit value = 6000 $\mu\text{S}/\text{cm}$
 - Conductivity of condensate : < 10 $\mu\text{S}/\text{cm}$
- Iron content max. 0.1 mg/l
- Max. flow speed 25 m/s.
- For the use of district heat, the same requirements are valid as for fresh water.

4.5.2 Compressed air

Adhere to the following compressed air quality according to ISO 8573-1:2010, class 7.4.4:

Class	Solid particles	Water	Oil
	Mass concentration [mg/m ³]	Dew point under pressure, steam [°C]	Total oil ratio (liquid, aerosol and fog) [mg/m ³]
1			
2			
3			
4		≤ +3	5
5			
6			
7	5-10		

Delivery and operating instructions

5. Washer Extractors

5.1 Setting up the machine

Place the machine on a sufficiently load bearing and level floor.
Adhere to the following:

- Installation drawing
- Space requirement for service work and operation
- Position in relation to the supply and return connections (three-phase current, water/process water, air, steam)

Ensure that the machine is installed horizontally and stable. To anchor the machine, drill holes in the size of the supplied adhesive anchors. The holes can be drilled when the machine is located at its operating position. Adhere to the installation instructions given for adhesive anchors. Tighten the adhesive anchor rods applying a torque of 210 Nm.

Please refer to the foundation plan for the precise position of the process water connection in conjunction with the holes to be drilled.

The concrete floor should be at least 150 mm thick and meet the quality standard BN 250. Place the supplied stainless steel plates beneath the machine feet at the machine corners onto the floor.

Cover open waste water channels running underneath the machine to prevent corrosion to the machine.

The lateral distance from the wall on the non-drive side and the opposite side should not be less than that indicated in the dimensions below to ensure that the doors can be opened for maintenance purposes (figure LH: Commercial version; figure RH: Pass through version; BD: min. wall spacing; FE: collision protection; BW: barrier wall).

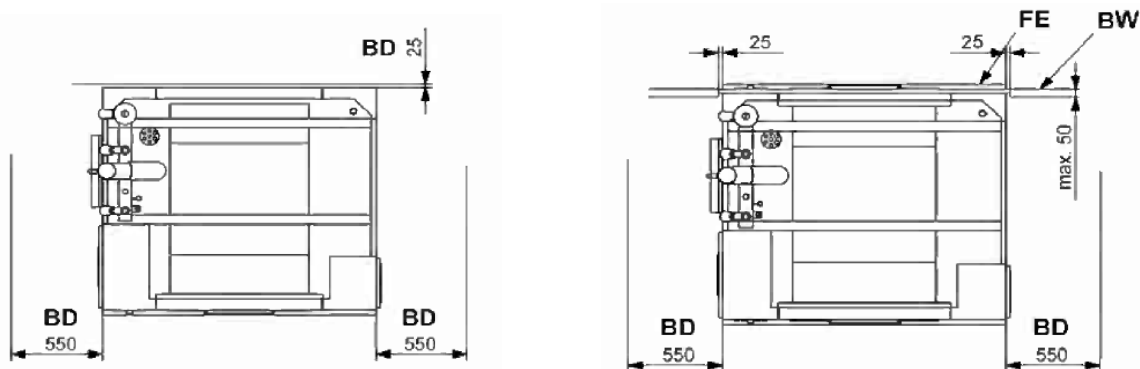

5.2 Machine in barrier wall execution

Barrier wall opening (optional for machine in barrier wall execution (BW))

When integrating the machine into a separating wall according to the national directives (for Germany according to BGR 500 «Operating equipment») between clean and soiled side, strictly adhere to the following opening dimensions:

	Width in mm	Height in mm
FAV 300	1450	1877
FAV 400	1650	1877
FAV 600	1700	2027
FAV 800	1950	2027
FAV 1000	2210	2027
FAV 1150	1950	2127
FAV 1450	2200	2127
FAV 1900	2640	2127
FAV 2250	2220	2409
FAV 2700	2450	2409

5.3 Installation of steam- and condensate line

The installation of the steam and condensate lines is in the sole responsibility of the customer. The steam and condensate lines must be installed properly and professionally - in accordance with industry-standard guidelines.

The installation instructions shown are intended to provide basic information to prevent particularly critical installation errors and do not replace a competent installation.

During installation of the steam pipe system, particularly observe the expansion and the discharge of condensate in the pipework.

5.3.1 Expansion of supply lines

Ensure that the longitudinal extension of the supply lines is allowed.

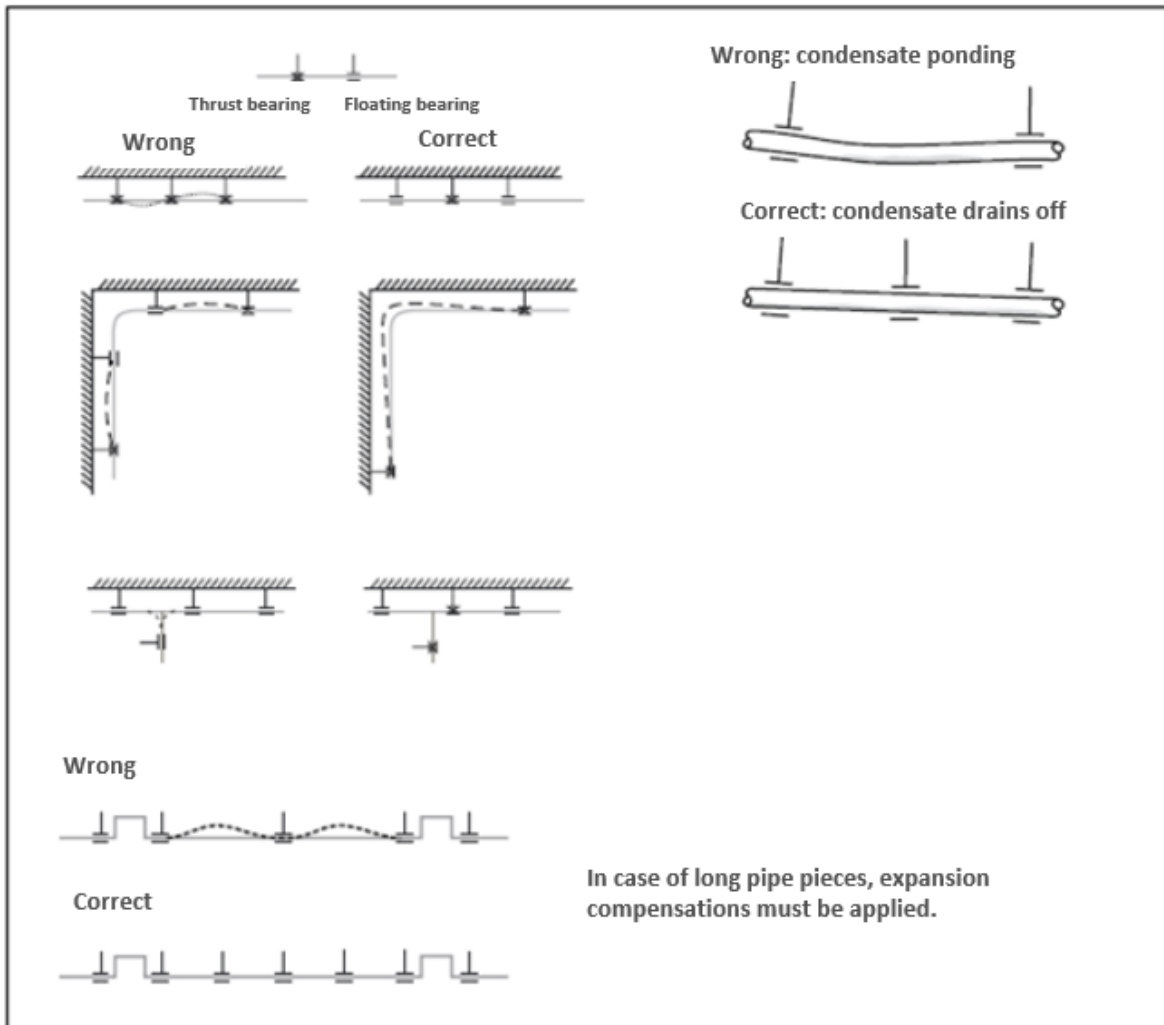

Source: Spirax Sarco GmbH

5.3.2 Discharge of condensate

If condensate is formed in the steam line, the following problems may occur:

- Increased risk of erosion
- Increased loss in pipe friction
- Obstruction of steam flow
- Difficulties in starting the pipe network
- Causing hydraulic pounding in the supply line which could destruct or endanger components and ironer

It is essential to drain the steam line.

5.3.3 Routing of the steam pipework with a descending gradient

Route the steam line in the flow direction with the descending gradient 1:100 to 1:200.

Provide additional condensate lines for pipe sections longer than 25m.

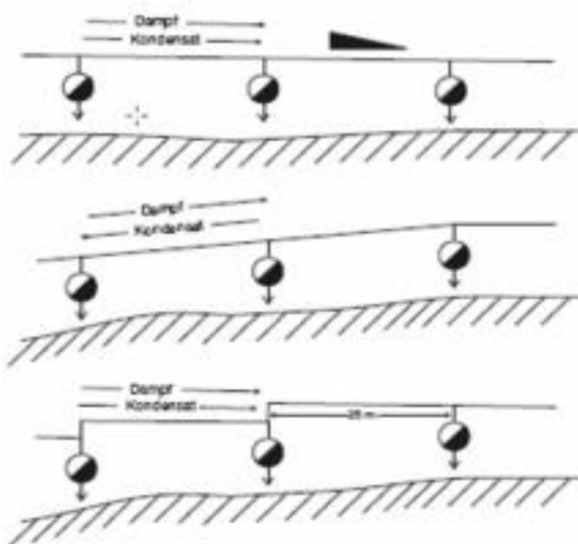

"correct"
standard installation

"wrong"

"correct"
installation with gradient in flow
direction or for larger height difference

Source: Spirax Sarco GmbH

5.3.4 Drainage of supply lines

The low points and ends of the supply pipe must be drained.

Rated width of steam line = rated width of condensate separator

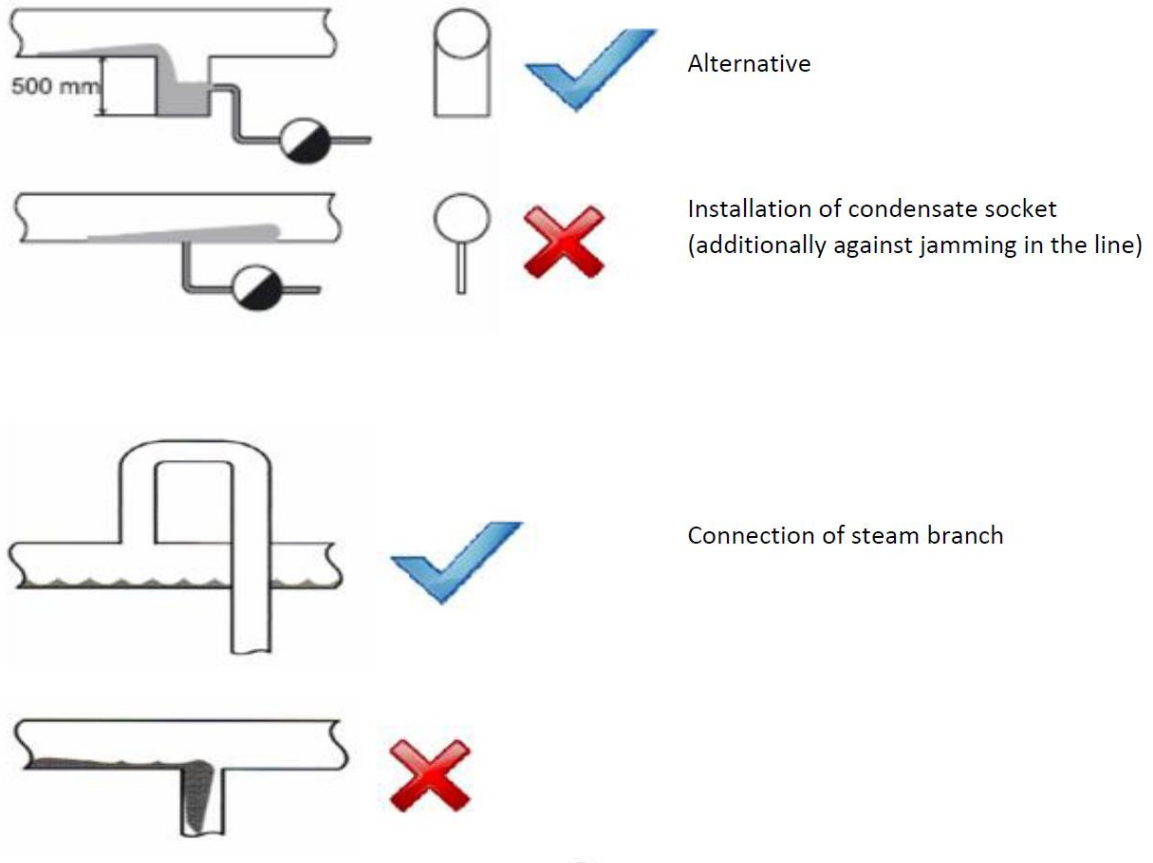

Water drainage directly before washer extractor

It is necessary to drain the steam line prior to the entrance of the washer extractor. The drawing shows an example designed by Kannegiesser. This type of drainage is supplied by Kannegiesser.

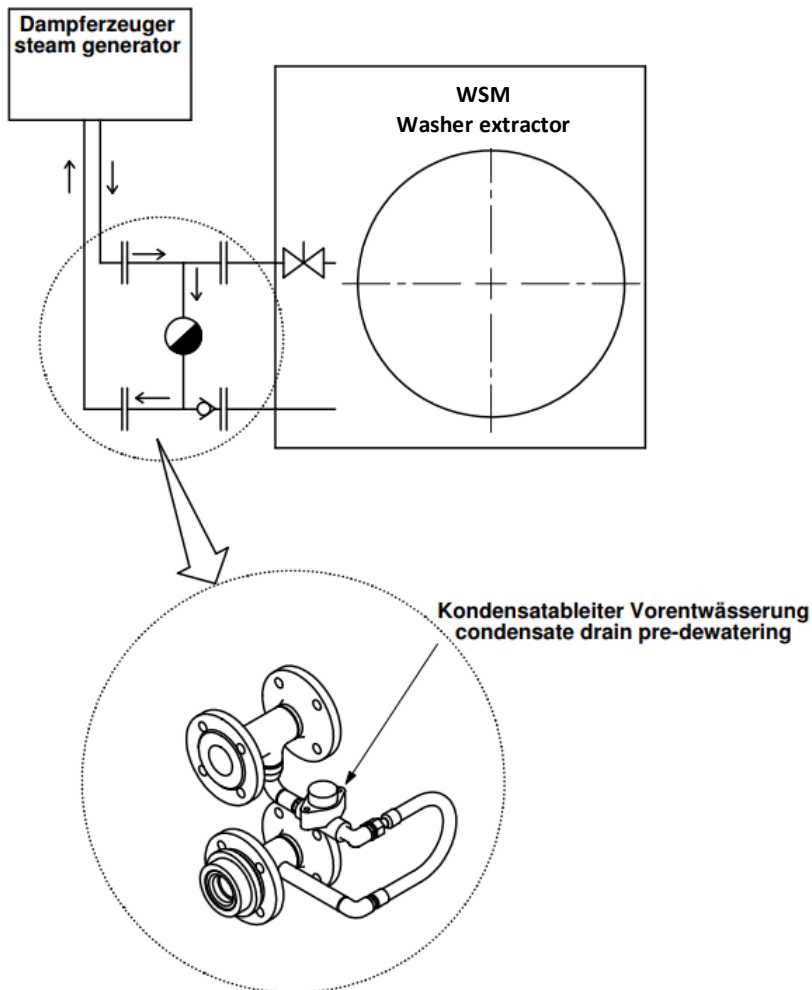

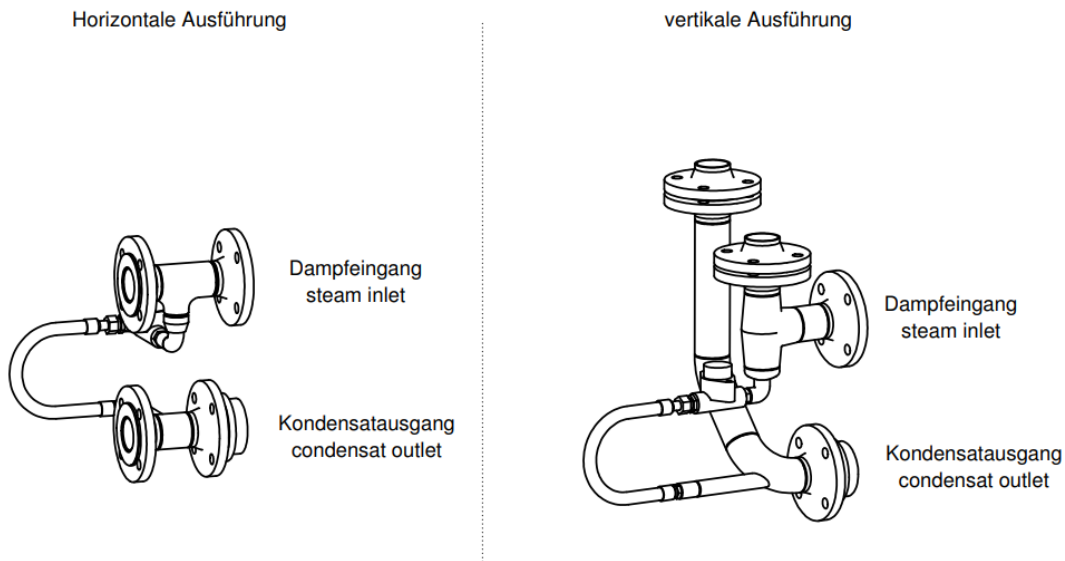

5.4 Medium connections

5.4.1 Electrical connection

Always have the connection made by an approved electrical engineer. Ensure that the electrical connection meets the (German) VDE regulations and the additional directives of your competent power supply company.

Connect the machine via an all-pole main switch. Ensure that the type of current and the voltage of the machine (see machine plate) coincide with the main voltage at the installation site. The supply cable is not part of our delivery.

Check whether or not a RCD fault current protection switch is to be installed into the supply line.

5.4.2 Water

The machine is supplied with two water connections as a standard (additional options are possible). The supply lines are connected rigidly or flexibly and must be connected without leaks to the intake valves on site.

Please refer to the technical data for the respective dimensions.

Ensure that the water pressure in the supply lines is at least 2 bar (2 - 4 bar are recommended) and does not exceed a pressure of 6 bar. Take respective measures if the pressure exceeds the specified values, e.g. install a pressure reducer in the supply line.

The machine is not equipped with its own DVGW separation. If this cannot be installed on site, operate the FAVORIT plus with a supply tank.

5.4.3. Waste water

The delivery scope includes a rubber bellows to be connected to the lye outlet pipe on the machine with a circlip. The temperature resistant pipework on site is connected to the other end of the spiral coiled tube.

5.4.4 Exhaust air

Connect the exhaust air to an open venting pipe. ATTENTION, NEVER TO A VACUUM SYSTEM. This will lead to incorrect level measuring results in the machine.

The accessories include a flexible hose for the connection between the exhaust air pipe on the machine and the exhaust air pipe on site. Install this hose such that the machine movements are compensated.

5.4.5 Steam

Install the steam connection to the machine steam valve with a descending gradient in the flow direction. Fit a filter and a valve or stop cock to shut off the steam into the supply line.

We recommend installing a condensate drain directly in front of the machine to prevent time losses and the entry of foreign objects (e.g. rust).

Ensure that the maximum pressure (bar) does not exceed the limit values specified in the data sheet. Check the steam connection for leaks at regular intervals. The steam valve is a Y-valve with flange connection.

Please refer to the technical data for the respective dimensions.

The throughflow direction of the valve is marked by an arrow.

5.4.6 Compressed air

Compressed air is required by the machine to control the respective pilot valves, the brake and the door locking (and the pneumatic detergent box, if installed). The supply line is equipped with a manual valve used to shut off the compressed air. Maintain the set air pressure of 6 bar at the installed compressed air assembly. The setting of the pneumatic springs depends on the type of machine.

Please refer to the technical data for the maximum operating and control pressures.

5.5 Medium quality

The water, steam and compressed air quality provided by the customer must comply with the generally accepted state of the art. The following limit and reference values apply :

5.5.1 Fresh water

At the entrance of the machine, the following fresh water quality is demanded :

- Iron content max. 0.1 mg/l
- Copper content max. 0.05 mg/l
- Manganese content max. 0.03 mg/l
- Chloride content max. 200 ppm (water should not react corrosive)
- Max. total hardness: 0.1 mMol/l Ca/Mg alkaline earth ions (0.56 °dH / 1 °f / 0.7 °E)
- Carbonate hardness to be considered in the wash process (> 15 °dH may lead to problems)
- Check the conductivity of fresh water regularly (if necessary, adjust processes and chemical dosing accordingly)
- Hygiene max. 100 cfu/ml, no pathogenic germs, no spores

5.5.2 Steam

At the entrance of the machine, the following steam quality is demanded :

- Conditioned soft water and boiler water according to DIN EN 12953-10 :
Boiler water:
 - Conductivity of boiler feed water: reference value = 3500 $\mu\text{S}/\text{cm}$, limit value = 6000 $\mu\text{S}/\text{cm}$
 - Conductivity of condensate : < 10 $\mu\text{S}/\text{cm}$
- Iron content max. 0.1 mg/l
- Flow rate max. 25 m/s
- For the use of district heat, the same requirements are valid as for fresh water.

5.5.3 Washing liquor

The following washing liquor quality is demanded inside the machine:

- Active chlorine content max. 250 ppm
- Active oxygen content max. 500 ppm
- Wash temperature 40-95 °C
- pH value in the washing zone > 7, in the neutralization chamber > 5.5
- Check regularly the conductivity difference between fresh water and extracted liquor (Delta > 1000 $\mu\text{S}/\text{cm}$ may lead to problems).

5.5.4 Compressed air

Adhere to the following compressed air quality according to ISO 8573-1:2010, class 7.4.4:

Class	Solid particles Mass concentration [mg/m ³]	Water Dew point under pressure, steam [°C]	Oil Total oil ratio (liquid, aerosol and mist) [mg/m ³]
1			
2			
3			
4		≤ +3	5
5			
6			
7	5-10		

Delivery and operating instructions

6. Ironers

The water, steam and compressed air quality provided by the customer must comply with the generally accepted state of the art. The following standard and respectively limit values apply.

6.1 Installation of steam- and condensate lines

The installation of the steam and condensate lines is in the sole responsibility of the customer. The steam and condensate lines must be installed properly and professionally - in accordance with industry-standard guidelines.

The installation instructions shown are intended to provide basic information to prevent particularly critical installation errors and do not replace a competent installation.

During installation of the steam pipe system, particularly observe the expansion and the discharge of condensate in the pipework.

6.1.1 Expansion of supply lines

Ensure that the longitudinal extension of the supply lines is allowed.

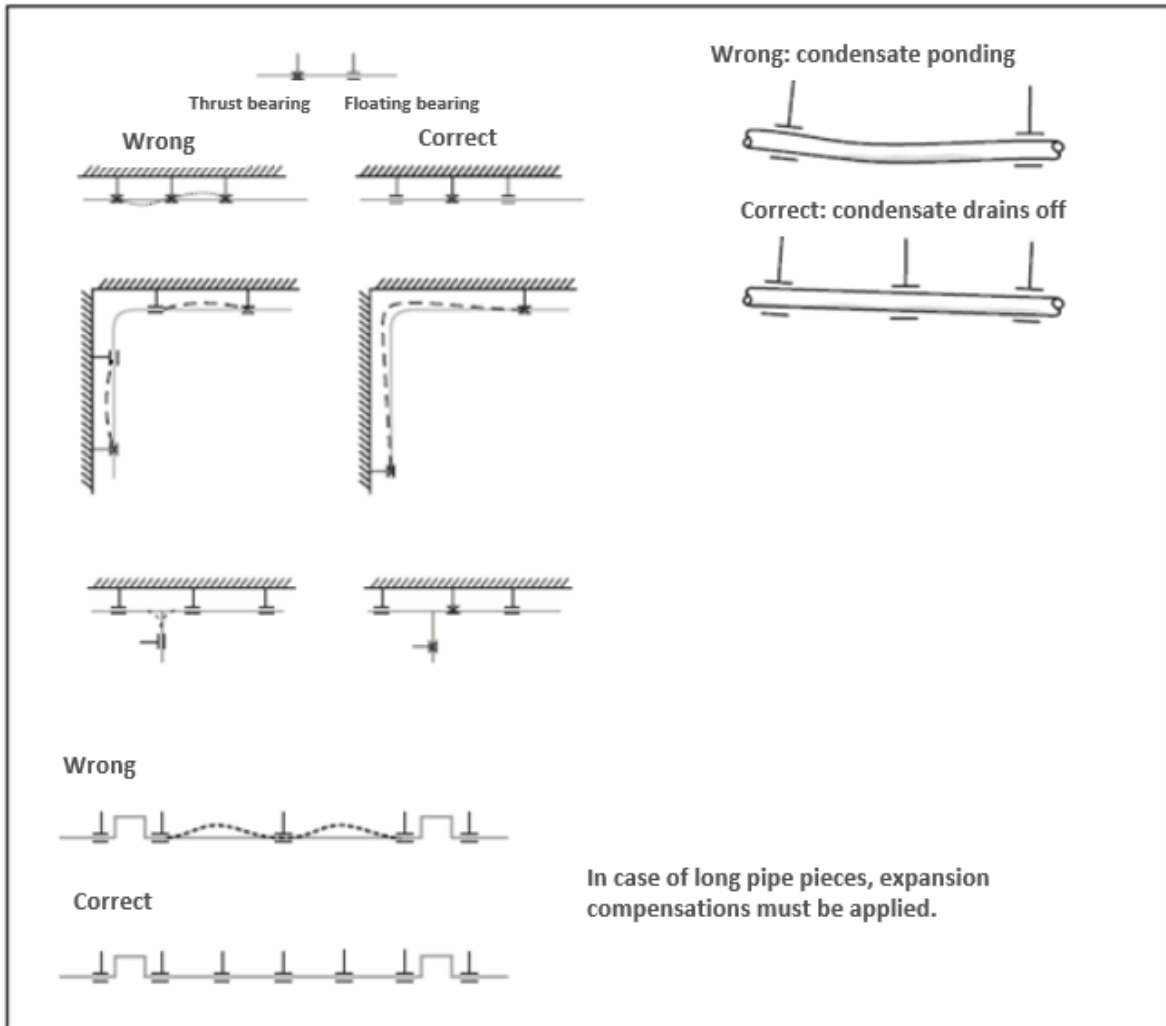

Source: Spirax Sarco GmbH

6.1.2 Discharge of condensate

If condensate is formed in the steam line, the following problems may occur

- Increased risk of erosion
- Increased loss in pipe friction
- Obstruction of steam flow
- Difficulties in starting the pipe network
- Causing hydraulic pounding in the supply line which could destruct or endanger components and ironer

It is essential to drain the steam line.

6.1.3 Routing of the steam pipework with a descending gradient

Route the steam line in the flow direction with the descending gradient 1:100 to 1:200.

Provide additional condensate lines for pipe sections longer than 25m.

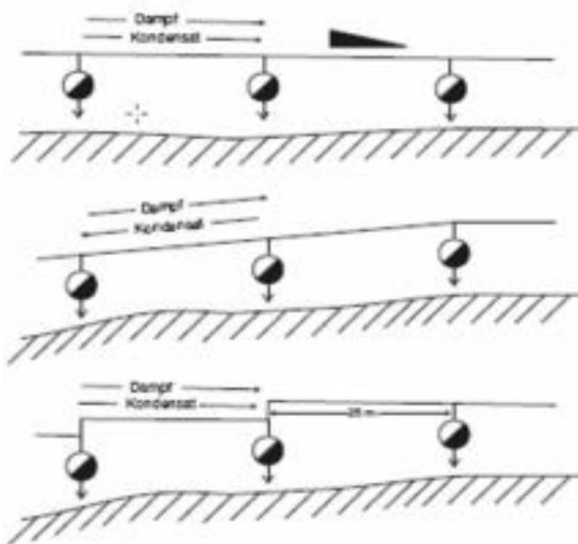

"correct"
standard installation

"wrong"

"correct"
installation with gradient in flow
direction or for larger height difference

Source: Spirax Sarco GmbH

6.1.4 Drainage of supply lines

The low points and ends of the supply pipe must be drained.

Rated width of steam line = rated width of condensate separator

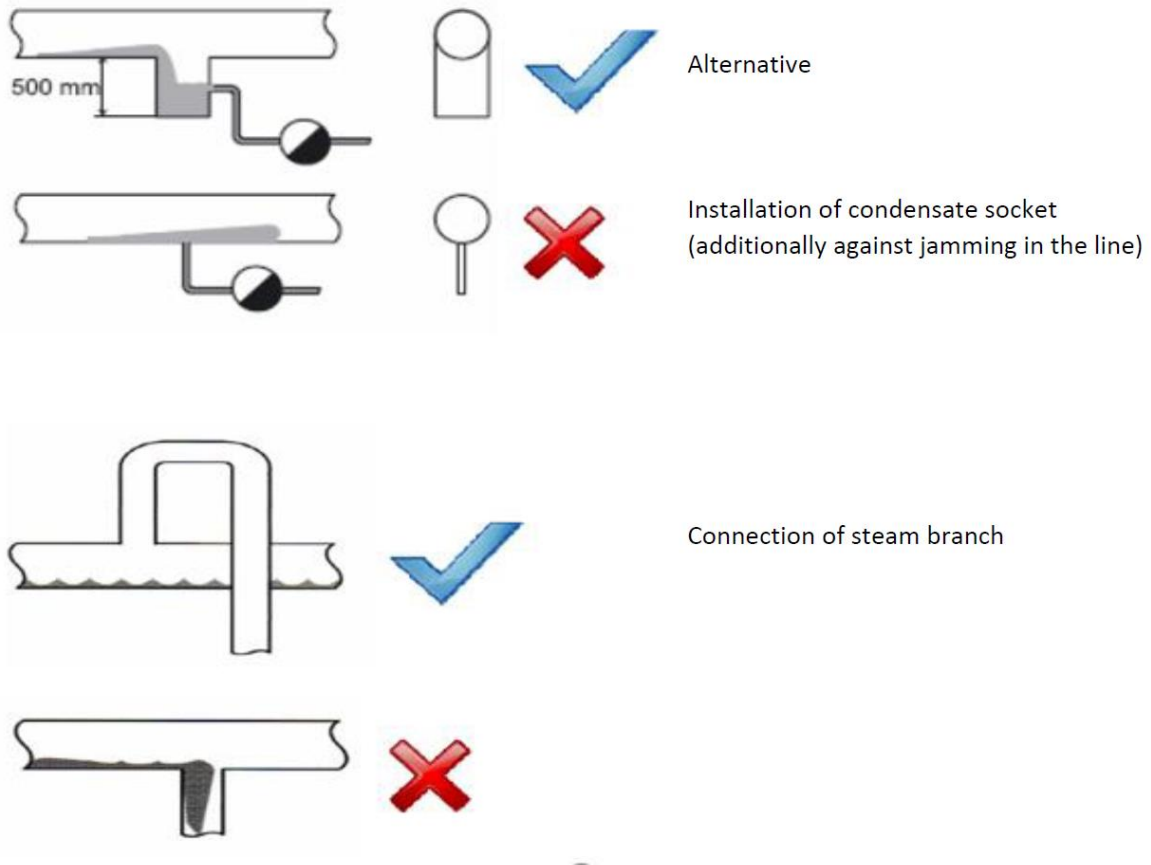

Water drainage directly before ironer

It is necessary to drain the steam line prior to the entrance of the ironer. The drawing shows an example designed by Kannegiesser. This type of drainage can be supplied by Kannegiesser.

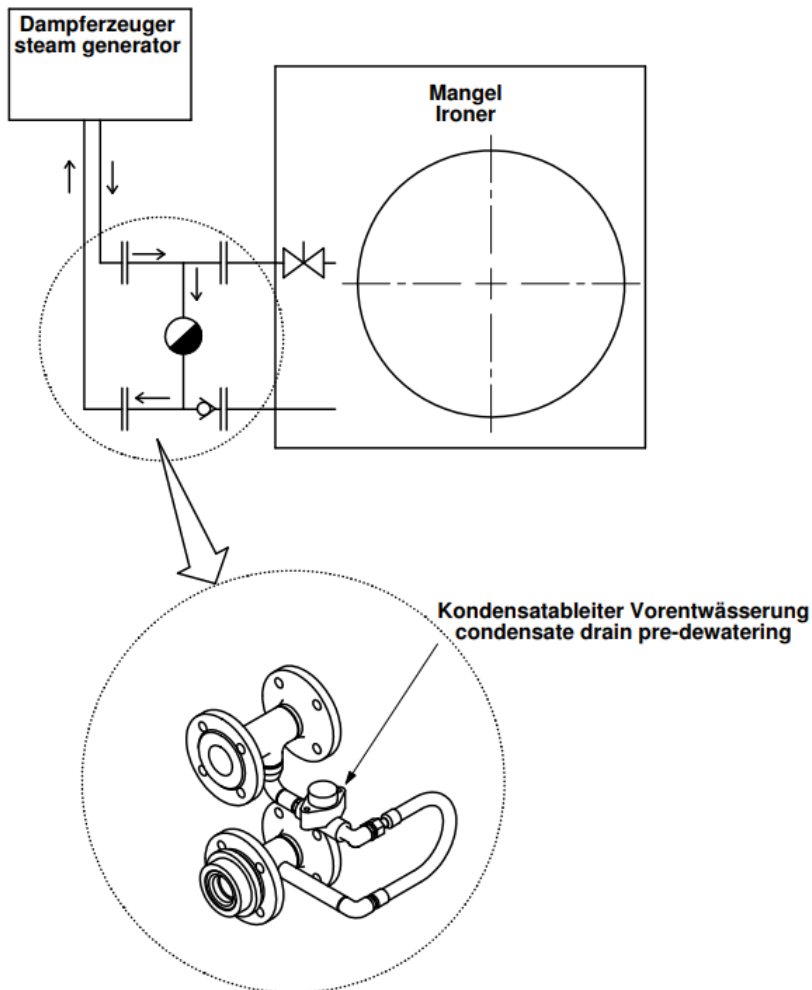

Horizontal execution
Horizontale Ausführung

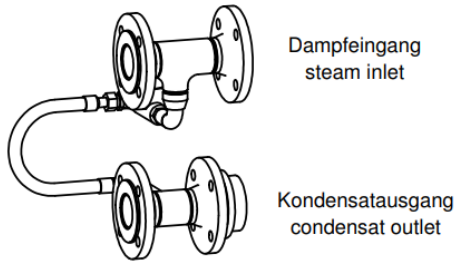

Vertical execution
vertikale Ausführung

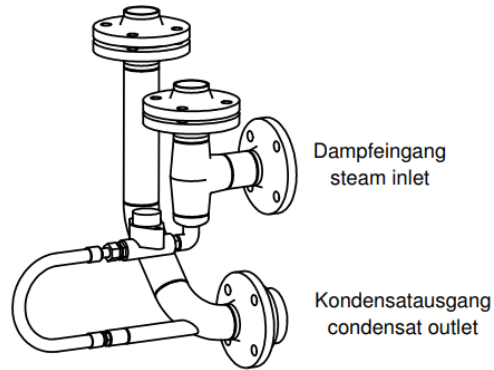

IMPORTANT !

Non-return valves are to be provided at ironer outlet. The condensate line may ascend quite high behind the ironer.

If the steam pressure collapses after closing the cut-off valves, the water column pushes the condensate back into the ironer via the condensate traps.

Condensate impacts might occur during start-up.

Note: This valve is included in the drainage assembly group with a non-return valve.

6.2 Medium connections

6.2.1 Compressed air

Compressor performance

The capacity of the compressor should be 20% to 30% higher than the compressed air consumption of the machine to ensure malfunction-free operation.

Supply line material

Install a supply line made of galvanized steel pipe or copper pipe to prevent rust from entering the compressed air system of the machine during operation.

Supply line diameter

Length of supply line	Diameter
<= 10 metres	1/2"
> 10 metres	3/4"

Prior to connecting the machine, fit an air shut-off valve. Use a compressed air hose to connect the machine with the supply line to prevent the transmission of vibrations. The hose should have a length of approx. 400 mm (15.75 in.) and the same cross-section as the supply line.

6.2.2 Escape air and exhaust air

Technical data

For the technical data regarding the exhaust air connection, please refer to the machine data sheet.

General design regulations

Multiple versions are possible depending on the local conditions.

Admissible length of the escaping air pipework

Route the escaping air pipework in a straight line and on the shortest way to the outside. Please refer to the machine data sheet for the maximum back pressure.

Several machines

Never connect several machines to one escaping air pipework. Always install one escaping air pipework for each machine.

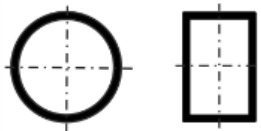
Cross section

The cross section of the piping may be rectangular or round. We recommend using pipes with a round cross section.

Diameter

The diameter of the escaping air pipework must not decrease in the flow direction.

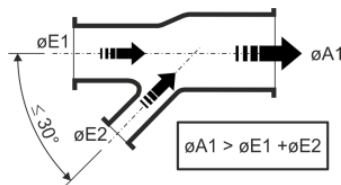
Junctions

Junctions must not be fitted at an angle larger than 30° in the flow direction. Try to avoid Y-tubes. The starting diameter must be larger than the sum of the inlet diameters.

Gradient in flow direction

The gradient in the flow direction may be between 1:100 until 1:200.

Directional changes

Only change directions in small increments. Use pipe bends with a large radius.

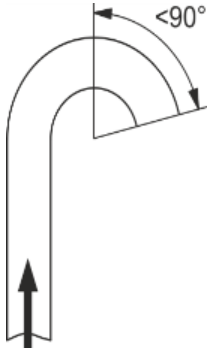
End of the escaping air pipework

Do not end the escaping air pipework with sieves or screens and install a drainage assembly. If the ends point upwards, install a Meidinger disc or end with a pipe bend $<90^\circ$.

6.2.3 Exhaust gas

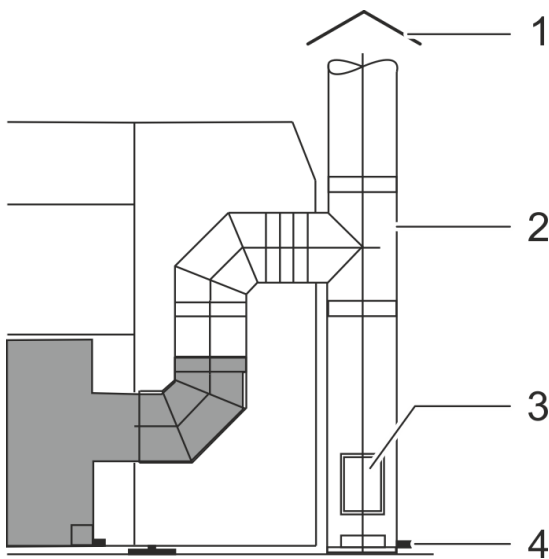

The bright section of the exhaust gas guide is to be installed by the ironer owner/user. Guidance must comply with the local, valid regulations. Contact the local, responsible authorities.

- 1 Protective hood
- 2 Insulation: at least 30 mm (1.18 in.)
- 3. Inspection opening
- 4. Condensate drain

6.3 Medium quality

The water, steam and compressed air quality provided by the customer must be state of the art. The following standard and respectively limit values apply.

6.3.1 Steam

At the entrance of the machine

- Conditioned soft water and boiler water according to DIN EN 12953-10.
- Flow rate max. 25 m/s
- For the use of district heat, the same requirements are valid as for fresh water.

6.3.2 Compressed air

Adhere to the following compressed air quality according to ISO 8573-1:2010, class 7.4.4 :

Class	Solid particles	Water	Oil
	Mass concentration [mg/m ³]	Dew point steam [°C]	Total oil ratio (liquid, aerosol and mist) [mg/m ³]
1			
2			
3			
4		≤ +3	5
5			
6			
7	5-10		

6.4 Advice for gas-heated ironers

During commissioning of gas-heated ironers, control measurements concerning gas emissions are required on site to be able to provide inspection reports and certificates for the gas burners by respecting special rules and regulations, in particular local and regional directives, ordinance on firing installations as well as instruction of legal gas suppliers.

These services are not rendered by KANNEGIESSER and are therefore not included in the quoted price.

It is recommended to get in contact, duly in time of planning, with the relevant gas supplier or specialist as well as with the local authorities. An adjustment of the burner can be carried out by Kannegiesser, but has to be quoted separately.

In case of conduct by the customer of gas-heated ironers contrary to the above and damages might occur hereby, the customer holds KANNEGIESSER and members of the KANNEGIESSER Group free and harmless of any claims from a third party, in particular claims for compensation, regardless legal grounds and laws.

Delivery and operating instructions

7. Tunnel finisher

7.1 Steam-heated tunnel finisher

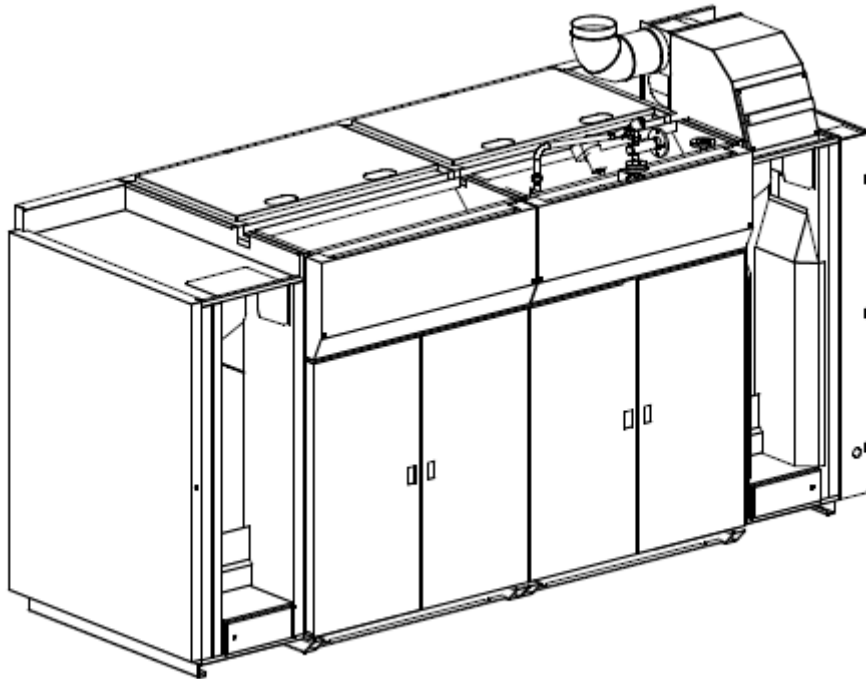

7.1.1 Steam line

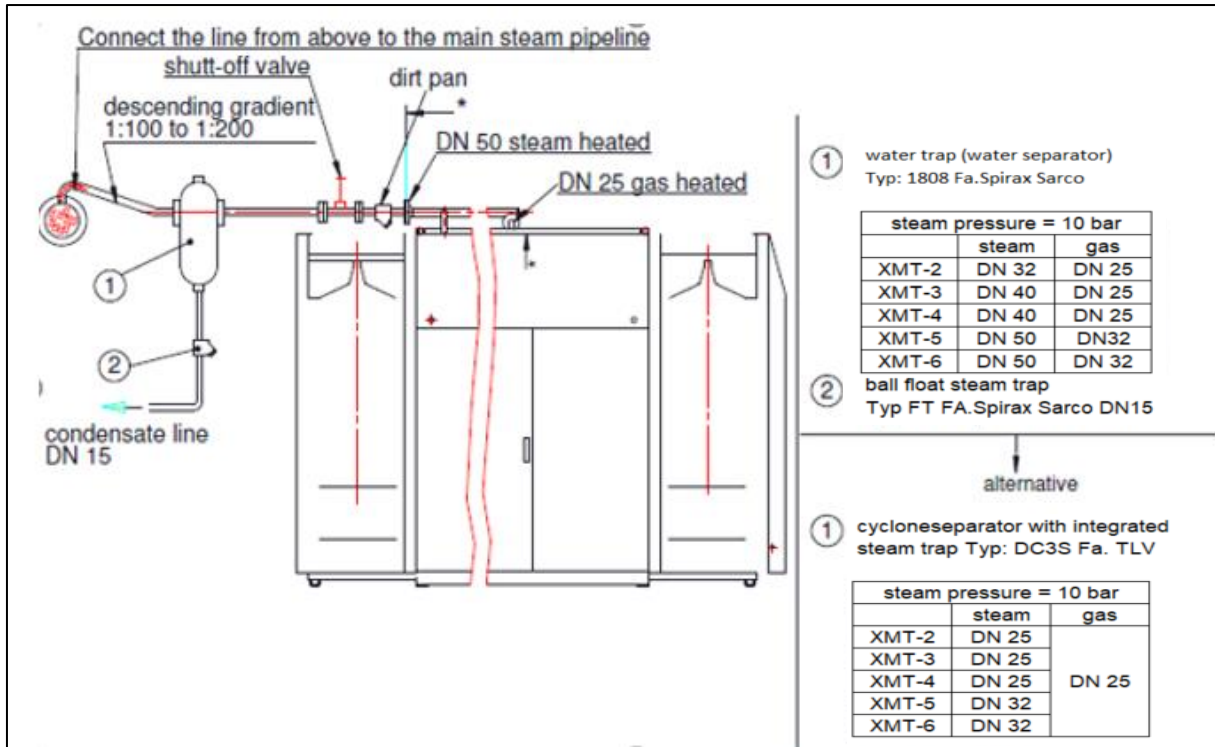

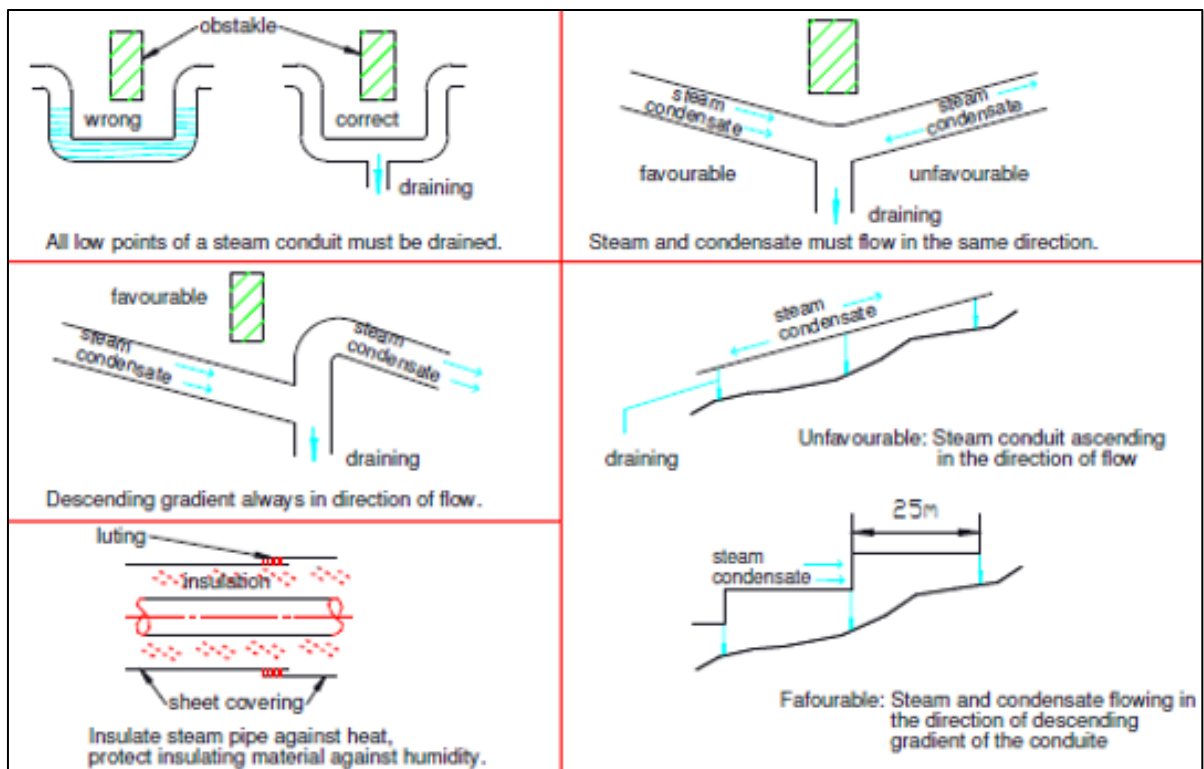

7.1.2 Condensate line

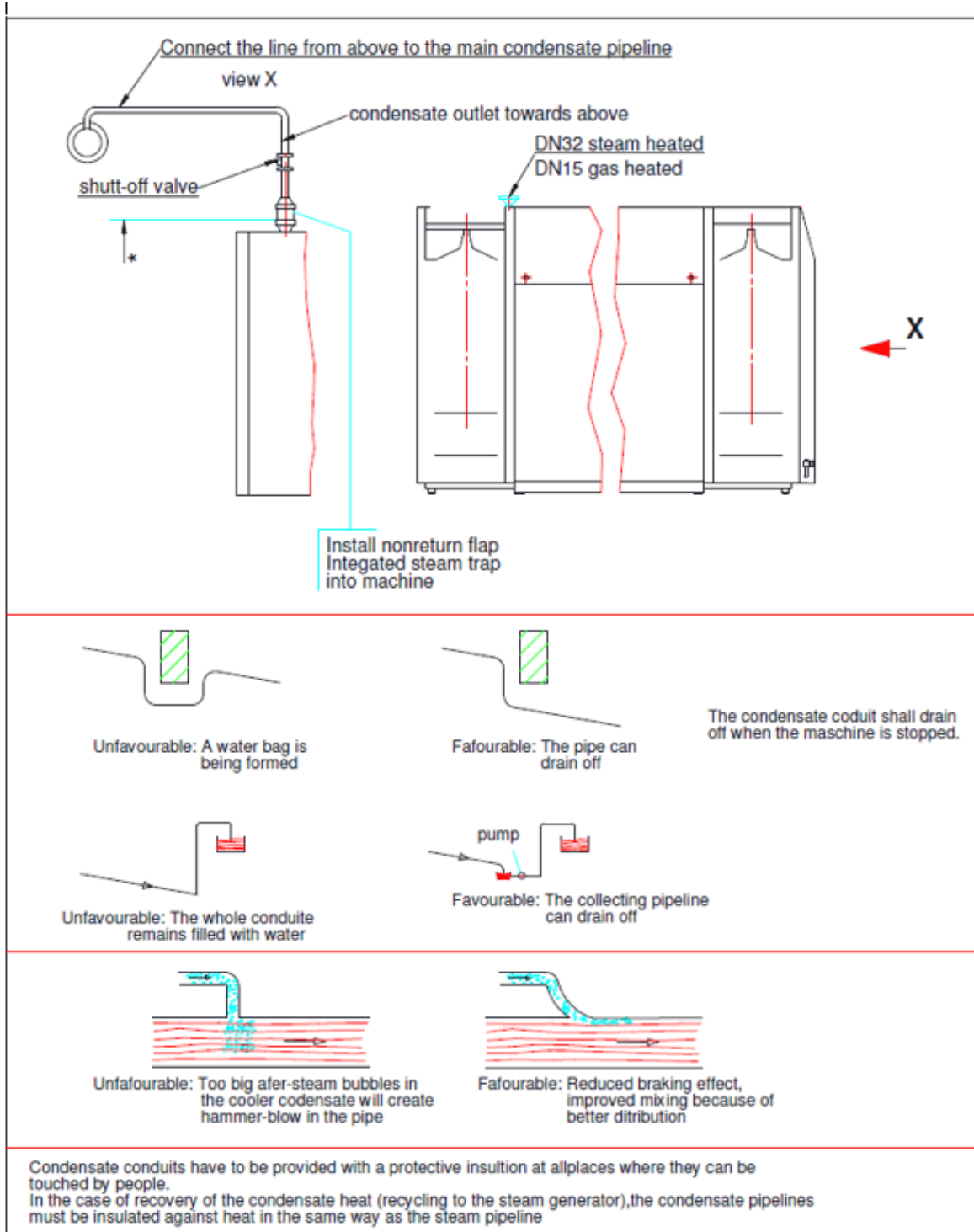

7.2 Gas-heated tunnel finisher

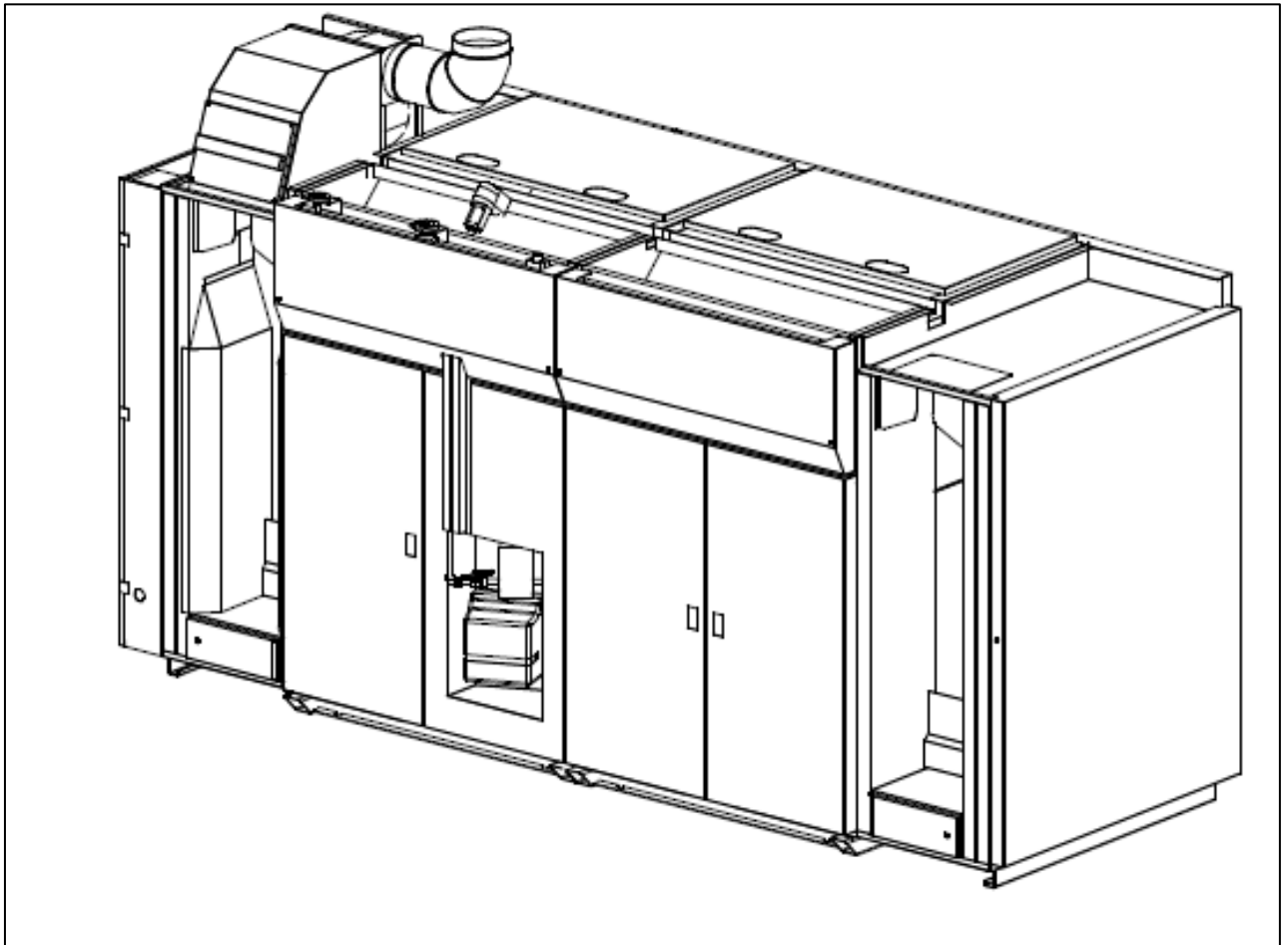

7.2.1 Gas line

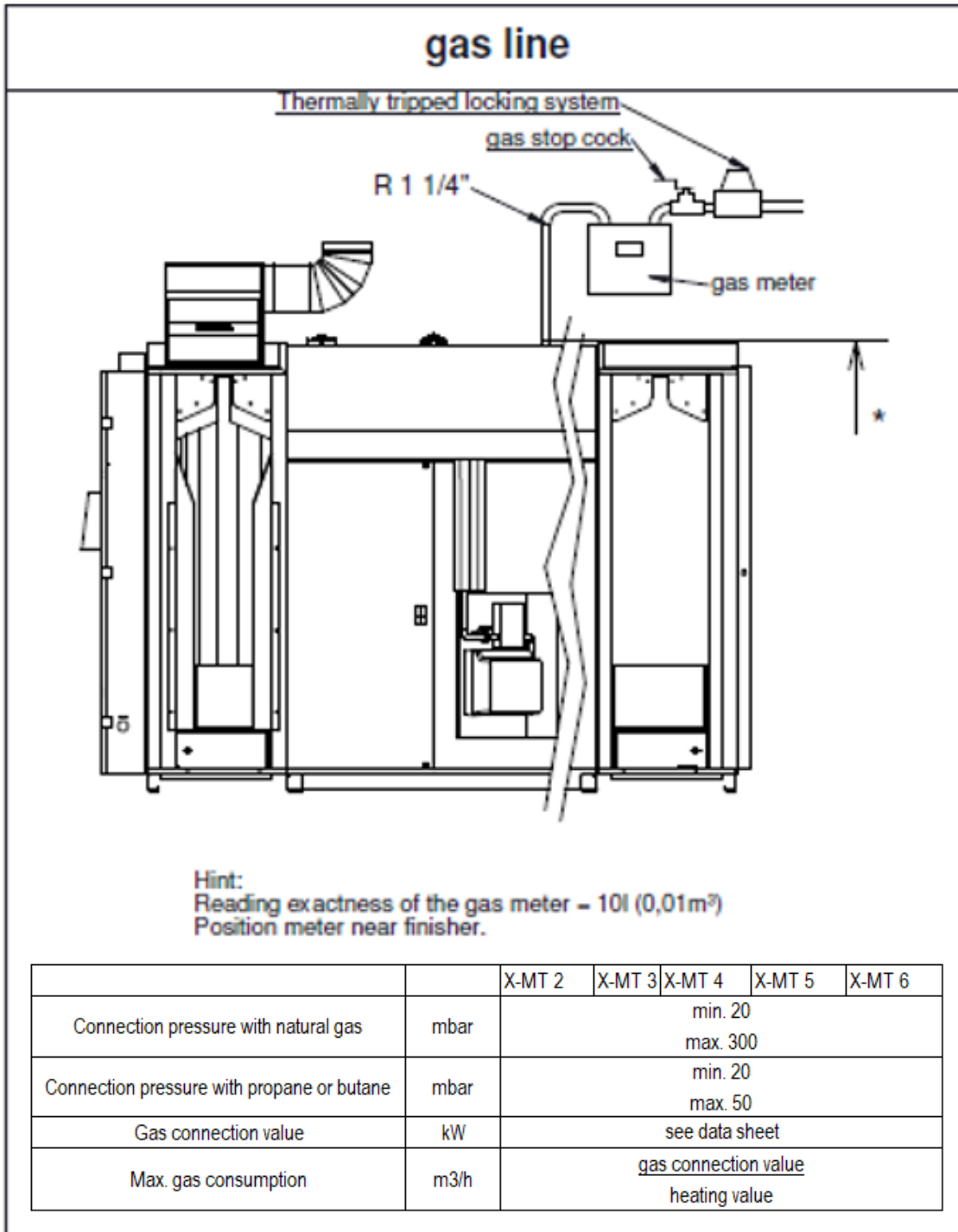

Important: Installation of the gas line only permitted by a specialized company with DVGW approval!

7.2.2 Outlet air line

Along with the outlet air, flue gases are exhausted through the outlet air line.

Special requirements are valid for the outlet air line:

1. Pipe material: Aluminium or stainless steel
2. Seal all cutting points or seams. Use temperature-resistant sealing material, e.g. silicone glue or sleeves.
3. Provide control openings for exhaust path controls. (Position and size according to responsible sweep association/guild)
4. Do not cover blow-out opening on roof with sieves or screens or similar.

7.2.3 Outlet air ducting

The gas-heated tunnel finisher XMT and SMT are seen as industrial process systems according to EN 746-2 and do not require DVGW certification (German association for gas and water). All series comply with the relevant regulations/directives.

Due to the respective burner capacities, a certain proportion of exhaust gas per hour is generated by stoichiometric combustion of gas. This proportion is included in the process air of the finisher. The air and exhaust gas mixture is extracted via the ventilator and transported to the outside by means of the exhaust air line to be installed on site.

The air and exhaust gas mixture, which is defined in the DVGW sheet G 631 A, is to be classified as exhaust gas, and not as exhaust air. The exhaust gas must be properly discharged via exhaust gas line/exhaust gas system.

The relevant standards, such as DIN EN 1443, DIN EN 15287 - 1 are to be considered. We recommend to instruct an expert company for technical execution.

A certified district chimney sweep must be contacted.

Pipe system made of metal tubes to discharge exhaust gas must be state of the art. Only use certified chimney pipes. We recommend the use of corrosion-resistant stainless steel when selecting the material of the exhaust gas pipes. For XMT series, exhaust air temperature is max. 100°C resp. 120°C for SMT series. When selecting components, consider the corresponding directives according to the respective state building regulations. An insulated pipe construction is advantageous to avoid that condensate is formed in the outlet air line as far as possible. Exhaust gas emerging into the room is not admissible.

The exhaust path control is required. Prior to the installation of the exhaust gas system, the suitable check and control openings must be adjusted by a certified district chimney sweep. Have the exhaust path control checked once per year according to the pertinent regulations.

Tunnel finishers are not subject to the 1st federal immission control act Germany (cf. §1, Para 2 No. 2 1. BImSchV) and therefore no exhaust gas loss or immission measurement (CO) is prescribed (German chimneys sweeper and control act KÜO of 16 June 2009)

Further technical information on outlet air and exhaust gas hygiene is available from the factory on request. Please contact your local Kannegiesser representative if required.

7.2.4 Advice for gas-heated tunnel finisher

During commissioning of the gas-heated tunnel finisher, control measurements concerning gas emissions are required on site to be able to provide inspection reports and certificates for the gas burners by respecting special rules and regulations, in particular local and regional directives, ordinance on firing installations as well as instruction of legal gas suppliers.

These services are not rendered by KANNEGIESSER and are therefore not included in the quoted price.

It is recommended to get in contact, duly in time of planning, with the relevant gas supplier or specialist as well as with the local authorities. An adjustment of the burner can be carried out by Kannegiesser, but has to be quoted separately.

In case of conduct by the customer of a gas-heated tunnel finisher contrary to the above and damages might occur hereby, the customer holds KANNEGIESSER and members of the KANNEGIESSER Group free and harmless of any claims from a third party, in particular claims for compensation, regardless legal grounds and laws.

7.3 Medium connections

7.3.1 Electrical connection

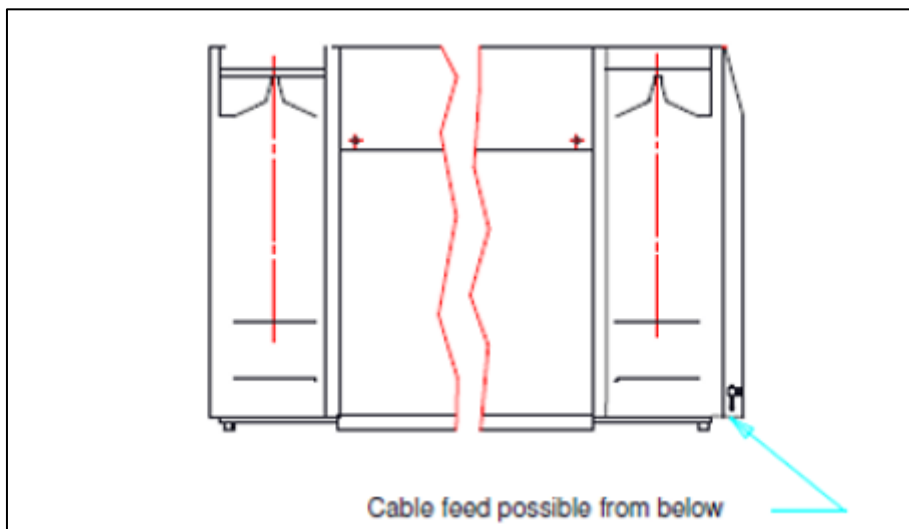

Connection of the machine to the main supply must be done only via the contact points shown and numbered on the wiring diagram annexed to this instruction manual and may only be carried out by a qualified electrician. Data about electrical connection loading is to be found on the machine data sheet.

Voltage and current must correspond to the values shown on the machine specification plate.

It is essential that the machine is correctly connected and protected according to the regulations supplied by the responsible electricity authority (earthing, fuse and neutral line). Earthing is made through the special grounding screw in the switch box. Further information concerning the electrical circuit inside the machine is found in the wiring diagram.

Motors: After connecting the electrical supply line, run the drive motor for a short period and check the direction of the rotation marked with arrows. In case of wrong sense of rotation, exchange phases.

7.3.2 Extinguishing device (optional)

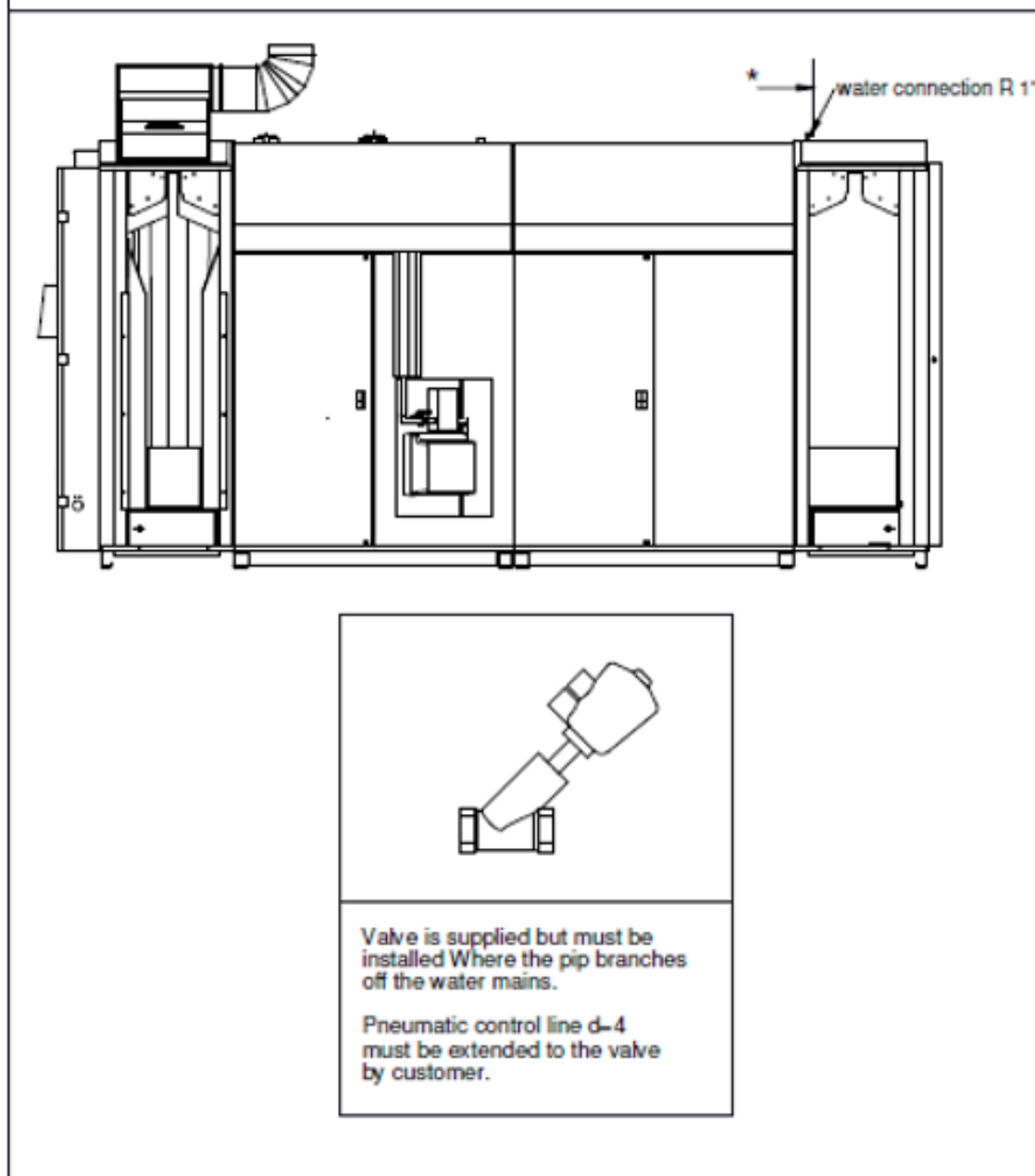

*) Kannegiesser scope of delivery

7.4 Outlet air line

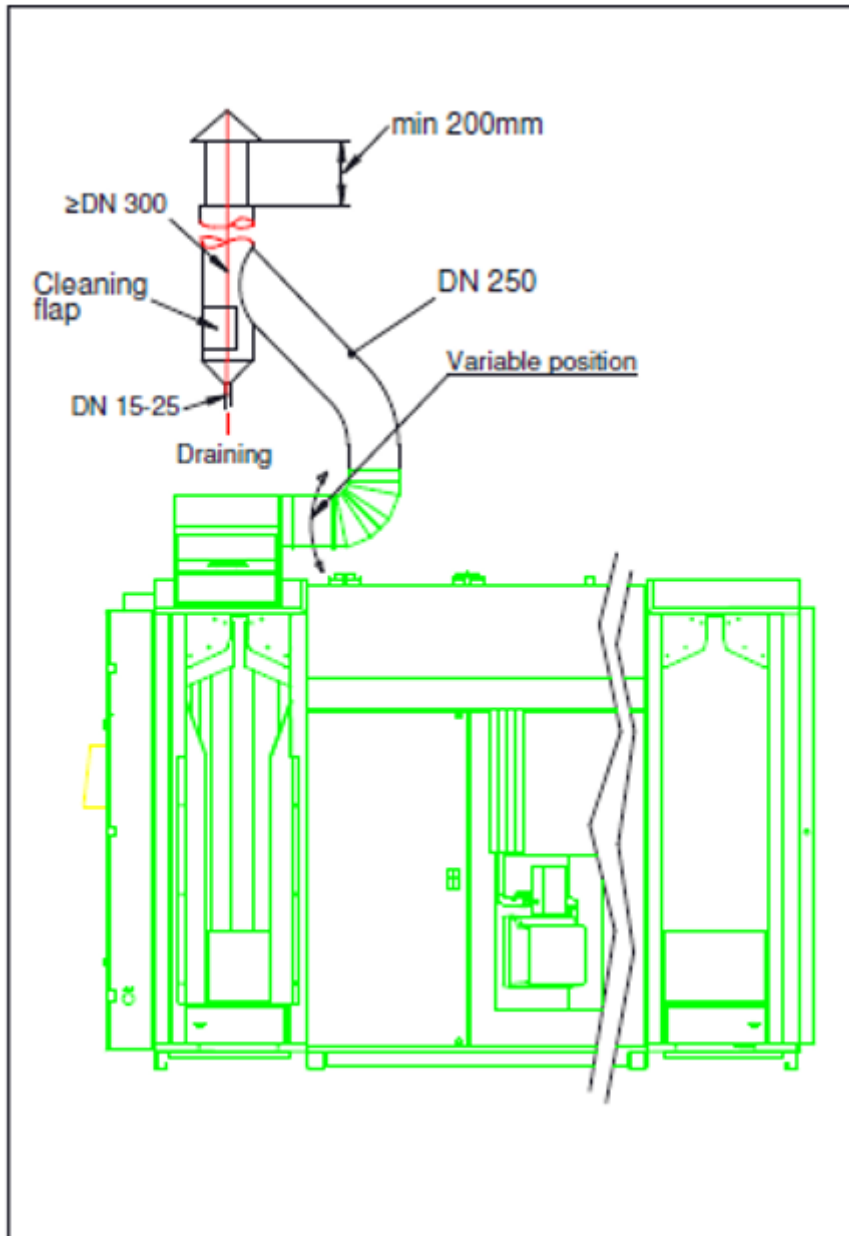

7.5 Other directives and regulations

1. The machine is not subject to the gas appliances directive. No special type examination or certifying are required. Gas burner and fittings are certified.
2. A flue gas loss measurement and repeated monitoring is not required according to the 1st federal immission control act (Germany) dd. 1997 (small heating systems).
3. According to the German KÜO (chimneys sweeper and control act), a flue gas path control (check for correct function of flue gas guidance and hazard-free flue gas behaviour) is required by the responsible chimney sweep association/guild (control opening).

Details :

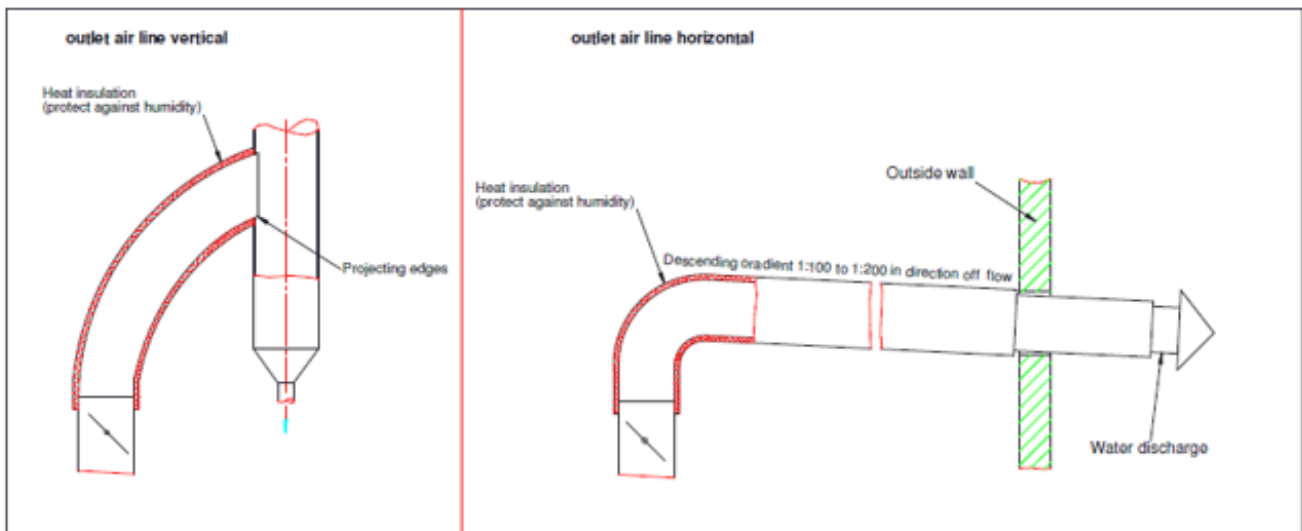

Delivery and operating instructions

8. RFT

8.1 Range of articles

Laundry articles, which meet the following criteria, can be treated by the Robofeed:

- Towels and bath mats
- Min. 500mm x 700mm (width x length in flow direction)
- Max. 1000mm x 2000mm
- Max. item weight 1000g or 650g/sqm

Different articles can be tested for handling at our factory. Please get in touch with your contact person.

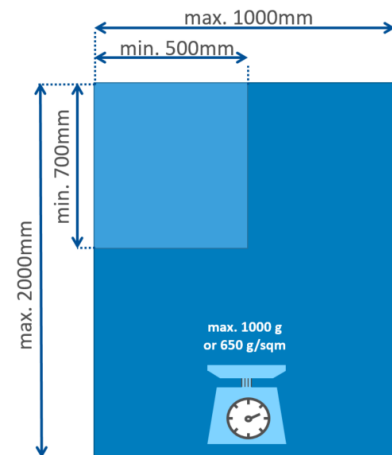

Not possible:

- Articles with rounded corners
- Square articles with an aspect ratio below 1:1,3
- Fitted sheets
- Incontinence pads
- Too large or too small articles

Too small articles, such as soap cloths, washcloths etc., are detected and discharged by the RFT. Laundry tub is included in the RFT standard version.

Too large or too heavy articles lead to a reduced hourly output. These articles remain inside the RFT and must be removed manually, latest on occasion of a customer- / category change.

8.2 Alignment of articles and folding pattern

At all times, the article is entered longitudinally and centered at the RFT.

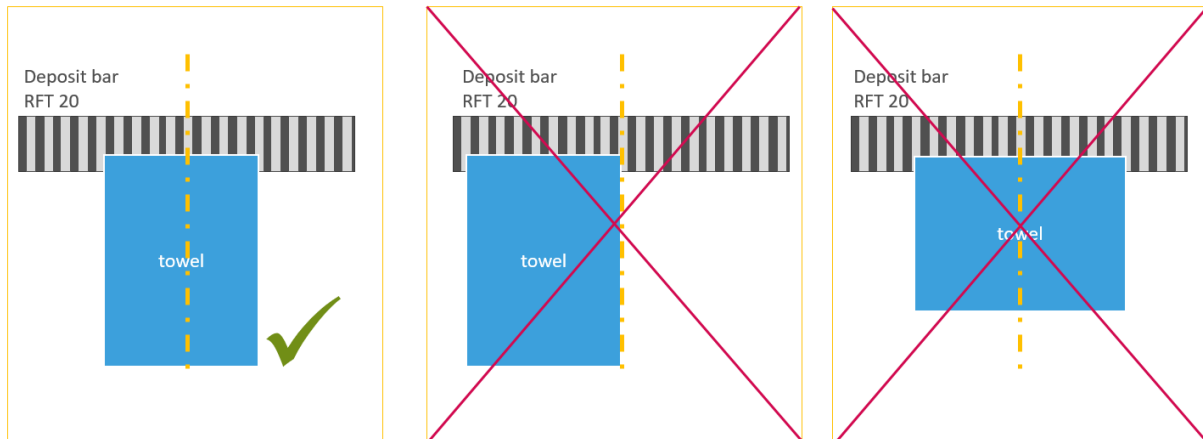

Not possible with the Robofeed RFT 20:

- Off center feeding of articles
- Crosswise feeding of articles
- Alignment of labels and patterns left/right, top/bottom

Hence, the articles on the Speedline can only be folded on edge - not cross folded - in a third fold or without length fold.

8.3 Sorting on the folding machine

- Sorting of same article sizes according to colour up to 4 criteria is possible. (option)
- Sorting according to length and width up to 4 criteria is possible.

Attention

- Batches with two different articles of the same size and colour cannot be stacked separately.

For single variety stacks, these articles have to be treated separately.

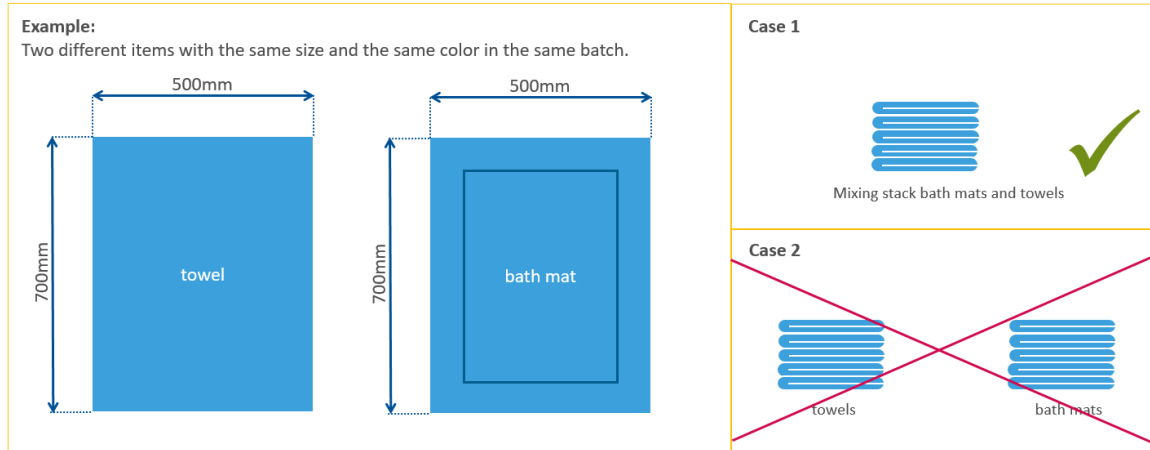

9. Network

A prerequisite for the network integration of Kannegiesser new and existing machinery is a network infrastructure to be provided on site before commissioning according to the Kannegiesser network plan. Requirement being the Kannegiesser Remote Access Unit (RAU) to ensure the network disconnection between the customer network and the Kannegiesser machine network. This increases security, virus protection and ensures controlled access to the Kannegiesser systems.

In addition to the network plan, the data connection points of each machine or the displays (DI) are drawn in the installation drawing or data sheet of the machine.

Provide the network range 10. 8. 0. 0 / 20 (255. 255. 240. 0) in a physical network or via the logical V-LAN. The network cables used for the network structure must at least comply with CAT 6 S/FTP.

Non-observance will lead to additional expenditure which will be charged by Kannegiesser.

Should the standard IP (10.8.15.254), which is reserved for the RAU, be not available for technical reasons, the following services must be provided by the customer and its infrastructure: NTP server, port management, DNS, routing, firewall policy, NAT.

Delivery based on the General Terms and Conditions of Herbert Kannegiesser GmbH for the delivery of data and information systems available on our website (www.kannegiesser.de).

9.1. Teleservice

Herbert Kannegiesser GmbH offers remote support and remote maintenance (Teleservice) for overall systems via internet-based connections. The teleservice solution allows to globally support the commissioning/start-up of new plants, maintain systems and support service technicians online during troubleshooting.

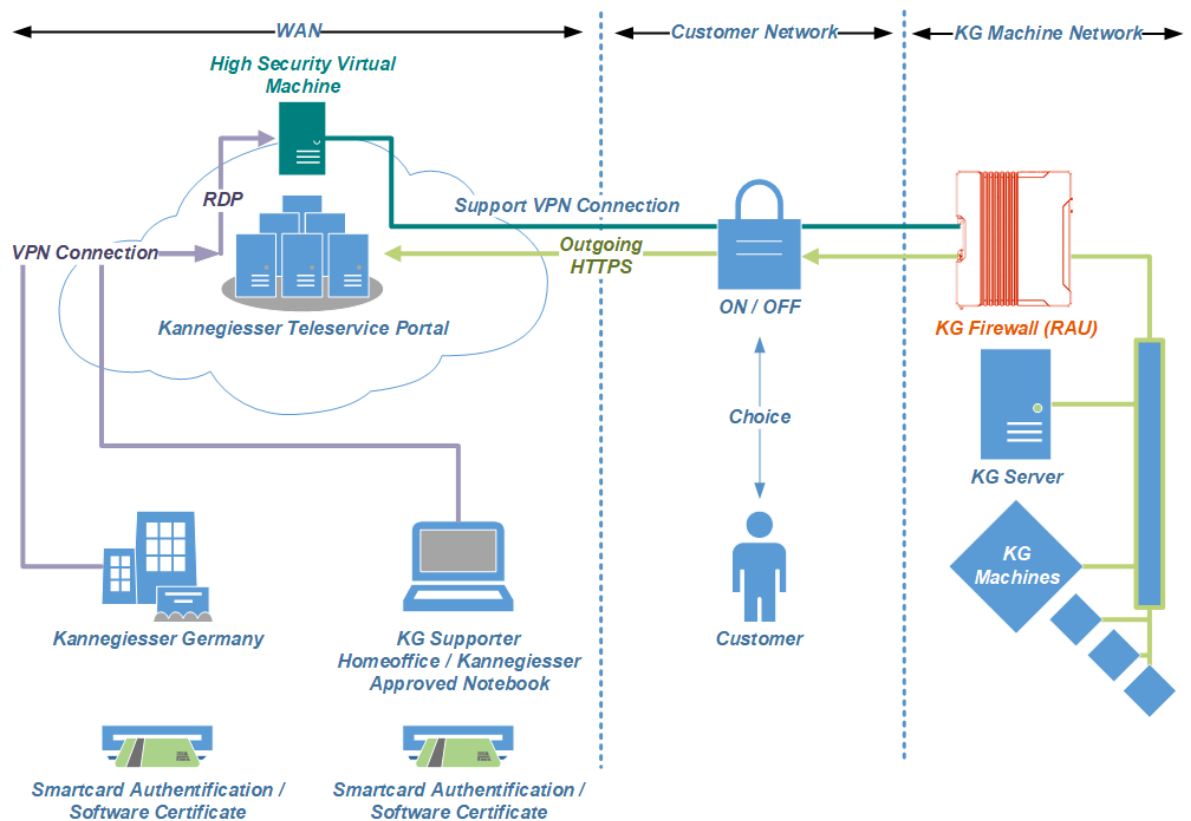

The Kannegiesser teleservice portal ("WAN" section) forms the central unit of the remote maintenance concept and is a closed communication environment. This portal is physically located in a high availability cloud with backup scenarios, uninterruptible power supply and fastest internet connections.

The Remote Access Unit (RAU) establishes an outgoing connection to the Kannegiesser service portal. The service portal provides several virtual computers that are tested, protected, certified and continuously maintained by the provider, equipped with special programs for optimal remote maintenance and thus guarantee the prerequisite for the fastest support. A connection to the Kannegiesser production network can only be realized by qualified Kannegiesser employees. In this connection, all participants are authenticated using a multi-stage process. Certificate-based smart cards are used in conjunction with PIN and passwords to ensure the highest level of security.

These security measures prevent Kannegiesser supporters from establishing a direct connection between their computer and the Kannegiesser production network. This does not create security gaps and do not allow viruses or other malicious software to penetrate the remote maintenance infrastructure.

The customer decides turning the key switch whether a VPN connection by Kannegiesser is allowed. In the "0" or "offline" position of the key switch, it is not possible to establish a connection to the device or to the production network (machines).



The following options are available for remote maintenance:

- RAU internet access via 5G/LTE/UMTS/DSL router
In this case, the customer provides a 5G/LTE/UMTS/DSL router to establish a connection to the RAU.
- RAU internet access via customer network
In this scenario, the RAU acts as a client (network participant) in the customer network. The customer ensures that the RAU can establish the outgoing communication with the teleservice servers via TCP 443 (HTTPS).

For this purpose, information such as IP addresses (customer net, customer firewall, DNS server, KG firewall, possibly proxy) are required to configure the RAU.

Depending on how the remote access is to be realized, the corresponding checklist must be completed and the network checked for functionality. The functionality of the Internet connection / access is ensured by the customer and is not in the responsibility of Kannegiesser.

Implementation of this solution must meet the following requirements:

1. Voltage supply 230V.
2. Internet connection
 - Port 443 (HTTPS) is required for the outgoing VPN connection.
 - Address: DHCP or static IP address and DNS for the firewall.
 - Connections via the HTTP proxy are possible.

Scenario 1 – RAU Internet access via 5G/LTE/UMTS/DSL router

Upstream of the RAU is a 5G/LTE/UMTS/DSL router which provides the Internet connection. The router is to be provided by the customer. The customer is responsible for the function, configuration and administration. The RAU establishes an outgoing VPN connection to the Kannegiesser teleservice portal via port 443 (HTTPS). The access information must be provided to Kannegiesser, if necessary, for the configuration of the KG Firewall (RAU).

For communication between the customer network and the Kannegiesser production network, a corresponding route must be added on the customer's side so that all packages are forwarded to the Kannegiesser production network via the RAU interface. For this purpose, a further port for the customer network is configured at the RAU itself.

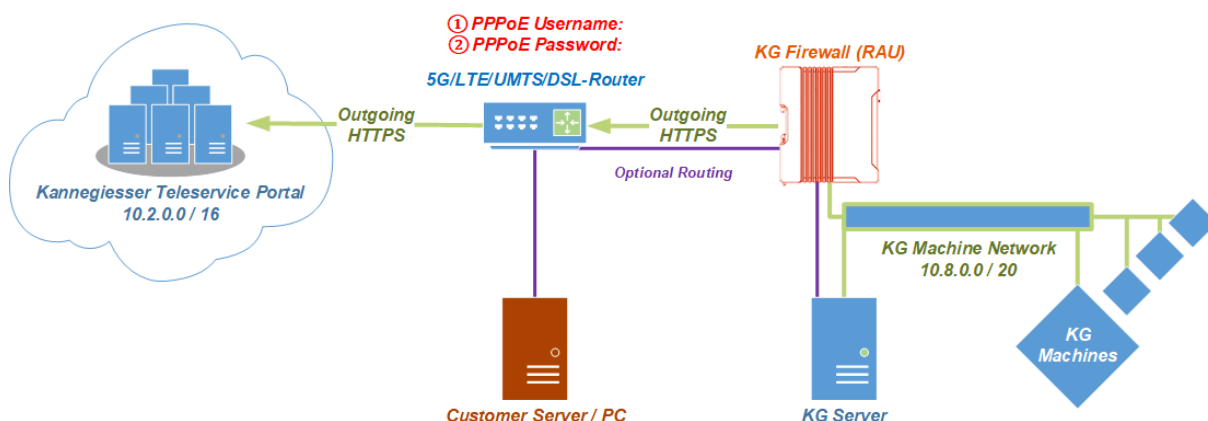

Scenario 2 – RAU Internet access via customer network

When implementing the remote maintenance access via the existing customer Internet connection, the RAU is installed as an interface between the customer network and the Kannegiesser production network. In order to establish a VPN connection, the RAU must be configured customer-specifically by the Kannegiesser service department and an outgoing connection via port 443 (HTTPS) must be approved by the customer.

For communication between the customer network and the Kannegiesser production network, a corresponding route must be added on the customer's side so that all packages are forwarded to the Kannegiesser production network via the RAU interface.

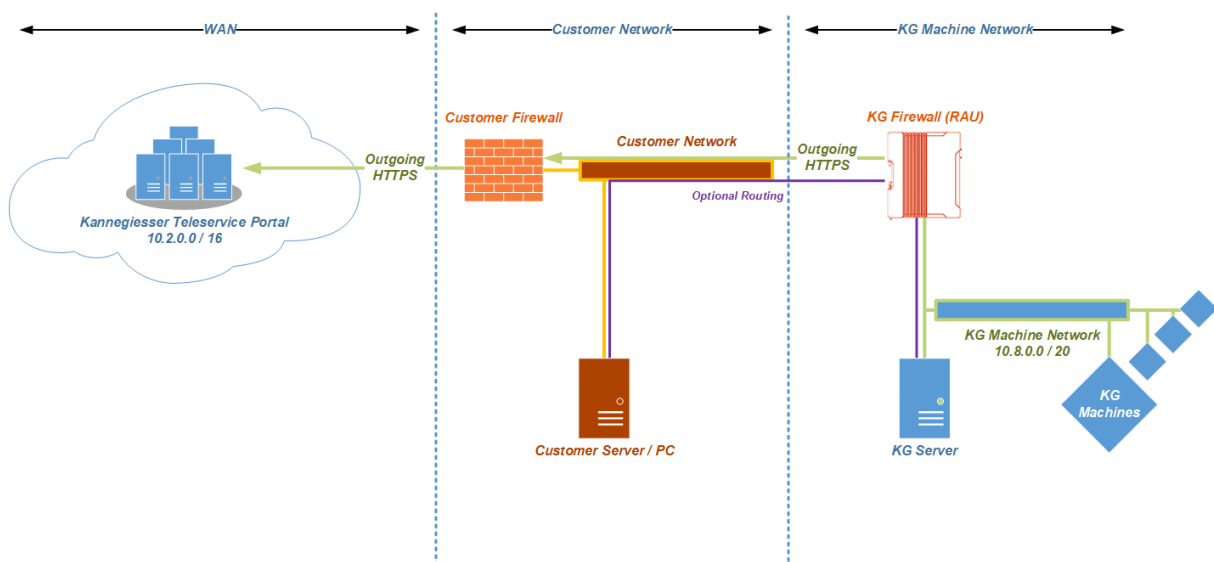

9.2. DataExchange Gateway

The standardized DataExchange Gateway was established to supply a license-free and practicable connection to general laundry data.

It consists of an online usable WebAPI with complete description and instructions for programmers of the ERP system.

This provides a repeatable interface with the following content:

- Master data for article, category, customer and employee, as essential basis for up- and downloading
- When downloading, a defined list of data-producing positions on the machines with corresponding performance figures:
 - number of quantities for counted individual parts per program
 - processed weights for systems with batch processing per program
- To check/identify the production readiness of a machine, the message text supplies/informs of the start and end of the messages.
- In addition, the corresponding message classes (stop, info and service) are transmitted in order to derive the status of the machine / systems.

In the opposite case, the master data on customers, articles, personnel and even data from other machine systems contained in the ERP system of the laundry can be transferred to the Kannegiesser System in a standardized manner.

In the event of additional requested information, data and/or even in individual cases the use of other data or file formats, the standard interface can be optionally and flexibly extended by individual customizing. In this case, we look forward to submitting you an offer.

For more on the functionality and documentation of the standardized DataExchange Gateway, please see this link:

http://develop.kannegiesser.com/apps/swagger-ui/?url=http://develop.kannegiesser.com/docs/apis/gateways.yaml#/Master%20Data/get_v1_master_data_articles

It is technically compliant with the latest standards and includes everything for automated documentation to design the web services.

9.3 Order processing contract according to GDPR (General Data Processing Regulations)

If you need an order processing contract, please contact us.

10. Proper storage of machines

Adhere to the following information should an interim storage of the machines be necessary:

- The temperature in the storage area must not exceed 50°C or be less than 0°C
- Direct sunlight should be avoided
- The goods must be protected from moisture, dust and other soiling
- The storage area must be protected against access by unauthorized persons