



Kannegiesser®
ETECH

AUTO WIND UP FEEDING TABLE

Providing an efficient means of
high-volume linen delivery to operators.

AUTO WIND UP FEEDING TABLE

Kannegiesser ETECH's AUTO WUFT is leading the way to improving productivity & safety with automated clean linen work station delivery.



OPERATOR BENEFITS

- Improved product & performance quality
- Stainless steel feeding tables provide an ergonomic height to reduce operator strain
- Foot pedal allows operator to wind belt up and down
- Presents goods in smaller batches to allow faster feeding
- Eliminate operator fatigue & ergonomic-related injuries
- Equipped with belt wind up & down positional limits
- Informs the operator about customer changes



Operators performing the repetitive motion of picking & placing linen consistently is a difficult task. By delivering an ergonomic work station with speed & safety in mind improve operator experience & performance.



- **DUMP**-Unwinds the belt fully then drops a batch into the AutoWUFT.
- **Customer Change**- Starts blinking when the overhead bag is a different customer than the one currently in the AutoWUFT.
- **E-stop**- Haults all functions of the AutoWUFT.

DESIGN BENEFITS

- The chute allows for easy transfer of goods from rail system bags, enclosed loading area fully protects operator during drops
- Linen load capacity is 500 lbs. for small pieces
- 11 second unwind time allows for no waiting from operator
- Automatically calls, stages & opens bags from the storage area
- Equipped with a 1/3 HP motor with configurations for customer's specific needs
- Optional dual sided feeding tables to allow faster processing

PLACEMENT CONVENTIONS & DIMENSIONS

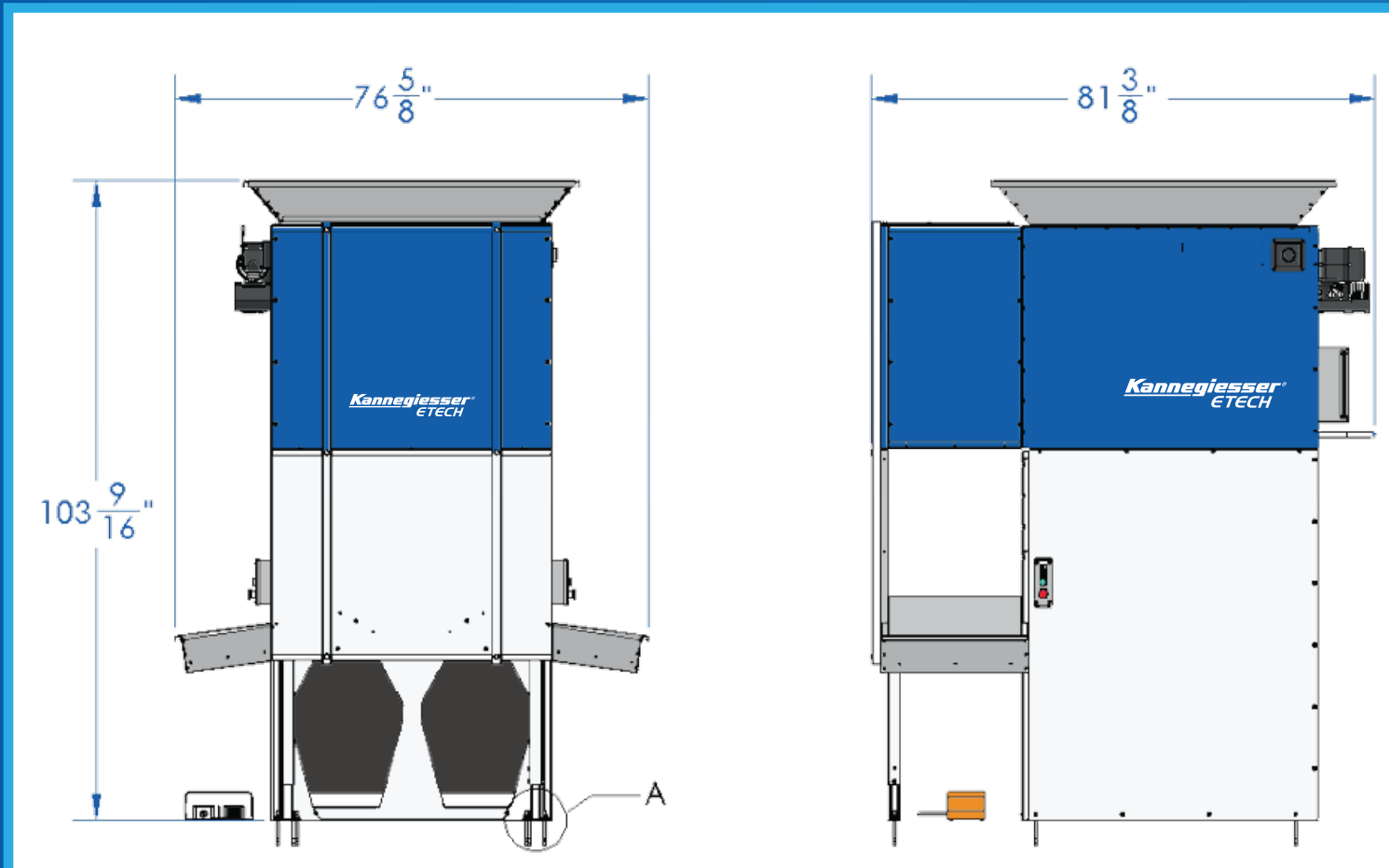

© 2021 KANNEGIESSER ETECH ALL RIGHTS RESERVED.

AUTO WUFT



Kannegiesser®
ETECH

Kannegiesser[®] ***ETECH***



**An ergonomic clean linen delivery work station
with speed and safety in mind to improve
operator experience and performance.**

Kannegiesser ETECH
Minneapolis, Minnesota

info@kannegiesser-etech.com
www.kannegiesser-etech.com

Subject to changes
Brochure shows optional equipment

Check out the
AUTO WUFT video

